

PowerAmp Design

EVALUATION KIT FOR MODEL PAD146

EVAL146

Rev B

INTRODUCTION

The EVAL146 assembled evaluation kit provides a convenient method to become familiar with the operation of the PAD146 operational amplifier before your application circuit is committed to production. Some assembly is required since some user selections are needed depending on the application. For example, a current limit resistor value needs to be selected by the user. Also, there are several PCB mounting options available.

Critical connections for power supply bypassing and compensation are pre-wired. Connections are also provided for the optional PAD131 Fan Controller Accessory Module. Diode clamps on each power supply and the output connections are provided for those applications in which significant inductive kickback may be found. Terminal strips are also provided for input and output signals and power.

ASSEMBLY STEPS

Please note that the #1 cause of problems for evaluation kit users is not reading and following the directions (all of them). The #2 cause of problems is poor solder joints (cold or bridging). Don't become a statistic. ✓ each step.

Refer to the Illustrated Parts List for the components mentioned in the assembly steps. Note that some heavy PCB copper planes and some heavy component leads are soldered in this kit. This may require a larger soldering iron tip and/or higher soldering iron temperatures than might normally be used. These steps are marked with an asterisk (*). Refer to the Illustrated Parts List for the components mentioned in each assembly step.

□ 1. Notice that the printed circuit board (PCB) is labeled on one side as the "DUT SIDE" and the other side as "CIRCUIT" side.

□ 2. As shown in the illustrated parts list, one or more of PAD's accessory cage jack strip CJS01 was used in the assembly of this kit. It may be advisable to use the cage jack strips in your production circuit board as well. The CJS01 cage jack sockets provide a convenient and inexpensive socket. Soldering and/or de-soldering the amplifier from the circuit board can be extremely difficult due to the high thermal conductivity of the amplifier's pins and substrate. You can find the datasheet for the CJS01 on the PAD website under the "Accessory Modules" tab.



Assembled EVAL146 with amplifier mounted.

□ 3*. Four current limiting (fault) sense resistors, R_s , are provided; one 0.01Ω , one 0.015Ω , one 0.02Ω and one 0.025Ω . These are 2512 surface mount resistors and are large enough that they may be soldered with a small tipped standard soldering iron. Refer to the PAD146 data sheet to determine which value would be best for your application. It is possible to adjust the current limit shutdown set point by removing J1 and adding appropriate values of R1 and R2. See application note AN-38 Fine Tuning Current Limit available on the PAD web site.

□ 4. D3 and D5 are transient voltage suppressor diodes and are not supplied since the type (breakdown voltage) varies with the application. They are not necessary for every application. They are most commonly used in application circuits where kickback from the load may force the supply voltage above the limits of the amplifier.











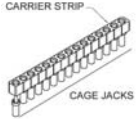

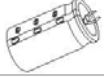





□ 5. The evaluation kit PCB can be mounted in several ways: **Option 1- Chassis mount.** Use #6 x 1/4" M/F hex standoffs, and #6 nut (neither supplied) attached to the PCB at the four corners of the PCB and the chassis. Use another similar standoff at the center area where the amplifier is mounted.

Option 2- Bench-top mount. Use the five rubber bumpers supplied. These are "stick-on" components. Remove the release paper from each bumper and apply the bumper to the square outlines on the "CIRCUIT SIDE" of the PCB.

Option 3- DIN rail mount. The PCB can be mounted to either 1 or 2 DIN rails. For mounting the PCB to one DIN rail press the adaptors into the PCB in the holes at the edges of the PCB at locations 1 and 2 from the "CIRCUIT SIDE" of the PCB. Make sure that the plastic tines have fully spread out on the "DUT SIDE" of the PCB. If mounting to 2 DIN rails is desired, mount DIN rail adaptors at locations 3, 4, 5 and 6 in a similar manner. The center-to-center dimension of the DIN rails is to be 2.00" [50.8mm].

- 6. Remove the 4 hex nuts from the mounting spacers of the amplifier.
- 7. Align the 4 studs of the mounting spacers with the mounting holes in the PCB. Be sure that the amplifier's pin 1 aligns with pin 1 on the PCB. Slowly lower the amplifier into the PCB, making sure that the pins of the amplifier and the cage jacks mate. Push the amplifier into the PCB until the mounting spacers meet the PCB.
- 8. Fasten the amplifier to the PCB with the 4 hex nuts previously removed. Do not over-tighten the nuts as this may strip the mounting studs. The provided plastic nut starter can assist you here.
- 9. If necessary, strip 1/8" of insulation from the wires connected to the fan. Twist and tin the wire ends. Insert the red wire into TS3 terminal labeled "+ FAN" and the black or blue wire into the TS3 terminal labeled "-". Or, if you plan to use the PAD131 Fan Controller Accessory Module, insert the fan wires similarly into the TS3 terminal labeled "+FAN CONTROL" and the black or blue wire into the TS3 terminal labeled "-".
- 10. Add components as necessary to evaluate your application circuit. You can utilize the evaluation kit schematic and PCB views to map out your circuit and components.
- 11. The amplifier **must** be compensated to operate correctly. See the amplifier datasheet on Page 4 under PHASE COMPENSATION. Your selected phase compensation capacitor will be installed at "C_C" on the evaluation kit PCB. A 100pF compensation capacitor has been installed but this may not be the best value for your application. If another value is better, remove and replace C_C as necessary. The kit also includes 470pF and 68pF capacitors. C_C must be a 200V rated capacitor and temperature stable, for example an NPO or X7R type.
- 12. If you have chosen to use the PAD131 fan controller module install it at this time, making sure that pin 1 on the module is aligned with the pin 1 marking on the PCB.
- 13. In some applications +/-VB and +/-VS use different power supply voltages. For these applications the jumpers on terminal strip TS1 that tie the VB voltages to the VS voltages can be removed as needed.
- 14. The evaluation kit assembly is complete. Be sure you have read and followed all the assembly steps. Inspect the circuit board for solder shorts or poor solder joints. An illuminated magnifier is helpful.
- 15. **Before applying power to your circuit set the power supply for ±20V and set the power supply current limit to approximately 100mA. Use little or no load at first. Apply an input signal and check the output with an oscilloscope to verify proper functionality. This step can prevent damaging the amplifier or the circuit board should there be some mistake in assembly**

Note that amplifier and accessory module are purchased separately.

✓	Ref	Qty	Description	Mfg/Distributor	Mfg. Part Number	Illustration (not to scale)
<input type="checkbox"/>	Amplifier Pins 1-30 + TPs	2	Cage Jacks w/carrier strip 32 wide	Power Amp Design	CJS01	
<input type="checkbox"/>	C1, 2, 5, 6, 9, 10	6	Capacitor, 1µf 250V	Murata/Mouser	RCER72E105K5B1H03B	
<input type="checkbox"/>	C3, 4	2	Electrolytic Capacitor, 470µF 200V	Nichicon/Mouser	LGU2D471MELZ	
<input type="checkbox"/>	C7, 8	2	Electrolytic Capacitor, 47µF 35V	Panasonic/Digi-Key	EEU-FC1V470	
<input type="checkbox"/>	JP1	1	BNC Jack	AMP/Digi-Key	5221123-2	
<input type="checkbox"/>	Cc	1	Capacitor 100pF 200V NPO	Kemet/Mouser	C316C101J2G5TA7301	
<input type="checkbox"/>	Cc	1	Capacitor 470pF 200V NPO	Kemet/Mouser	C322C471J2G5TA7301	
<input type="checkbox"/>	Cc	1	Capacitor 68pF 200V NPO	Kemet/Mouser	C322C680J2G5TA	
<input type="checkbox"/>	TS2	1	Terminal Block 5 Position	Phoenix/Digi-Key	1729157	
<input type="checkbox"/>	TS3	1	Terminal Block 3 Position	Phoenix/Digi-Key	1729131	
<input type="checkbox"/>	TS1	1	Terminal Strip 8 Position	Molex/Newark	38630-7808	
<input type="checkbox"/>	NA	2	Terminal Strip Jumper	Molex/Digi-Key	0380021478	
<input type="checkbox"/>	R _s	4	Sense Resistor	Vishay/Mouser Vishay/Mouser Vishay/Mouser Vishay/Mouser	WFMA2512R0100FEA (10 mΩ) WFMA2512R0150FEA (15 mΩ) WFMA2512R0200FEA (20 mΩ) WFMA2512R0250FEA (25 mΩ)	
<input type="checkbox"/>	D4, 6	2	Diode, Fast Recovery	ON Semi/Digi-Key	MUR410RL	
<input type="checkbox"/>	NA	5	Rubber Bumper	3M/Digi-Key	SJ5518	
<input type="checkbox"/>	NA	1	Jumper	3M/Mouser	923345-01-C (0.1 in)	
<input type="checkbox"/>	NA	1	Nut Starter	Menda/Jensen Tool	200	
<input type="checkbox"/>	NA	4	35mm DIN Rail Adaptor	Scidyne	121-0014	
<input type="checkbox"/>	NA	1	PCB	Power Amp Design	EVAL146	NA

CIRCUIT DIAGRAM

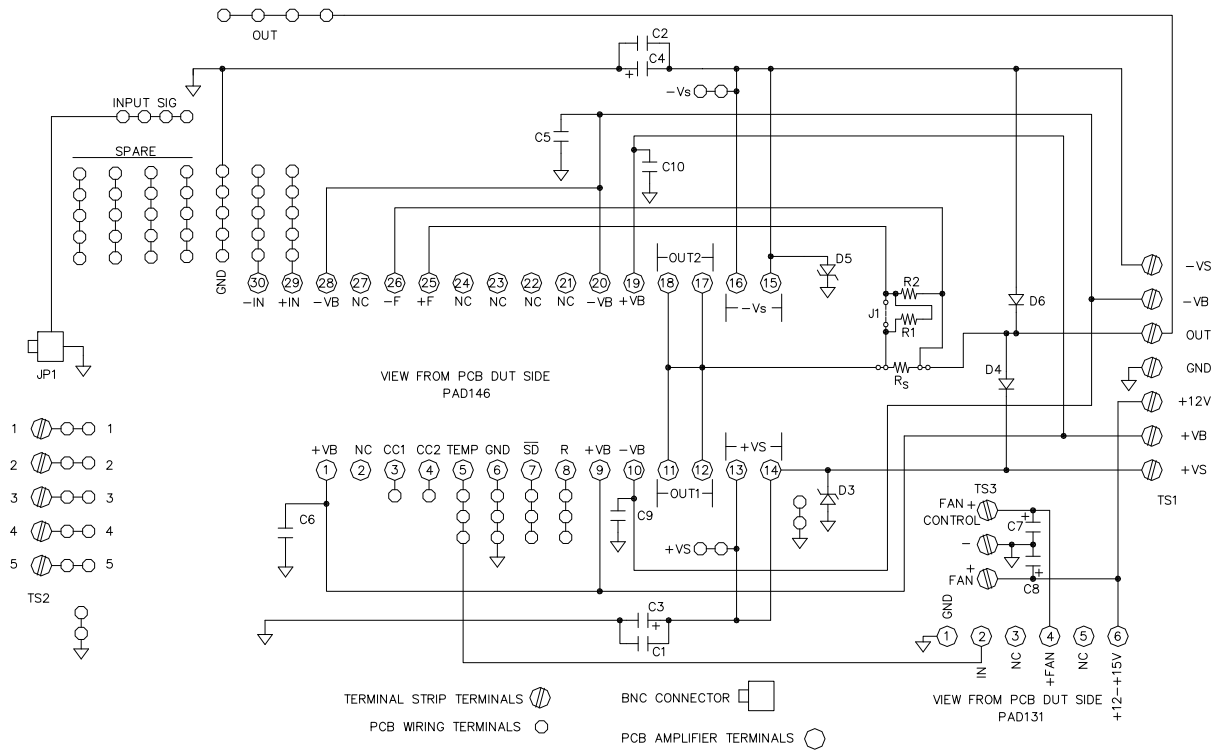

PowerAmp Design ♦ EVAL146 ♦ EVALUATION KIT FOR MODEL PAD146

TOP VIEW

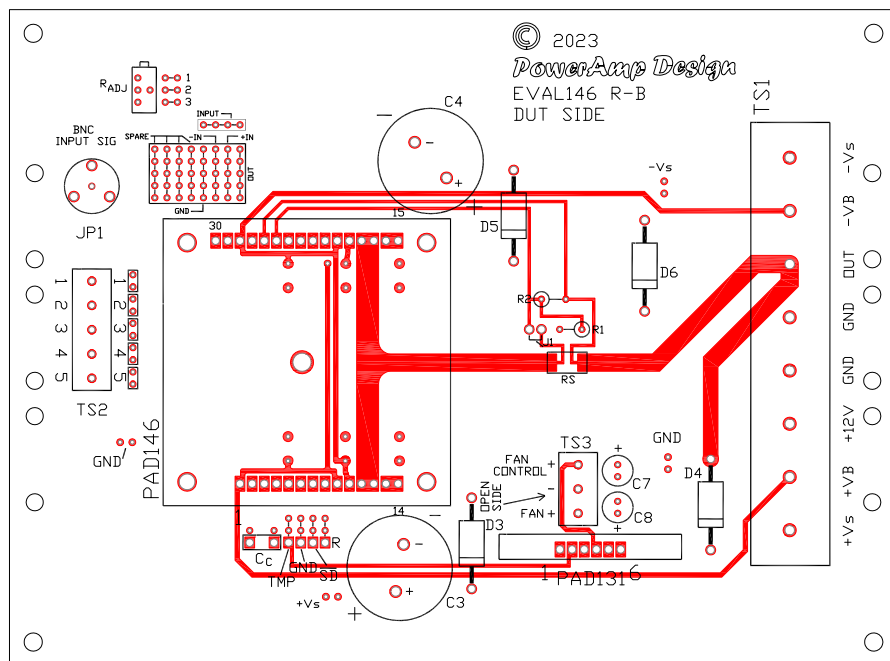

BOTTOM VIEW

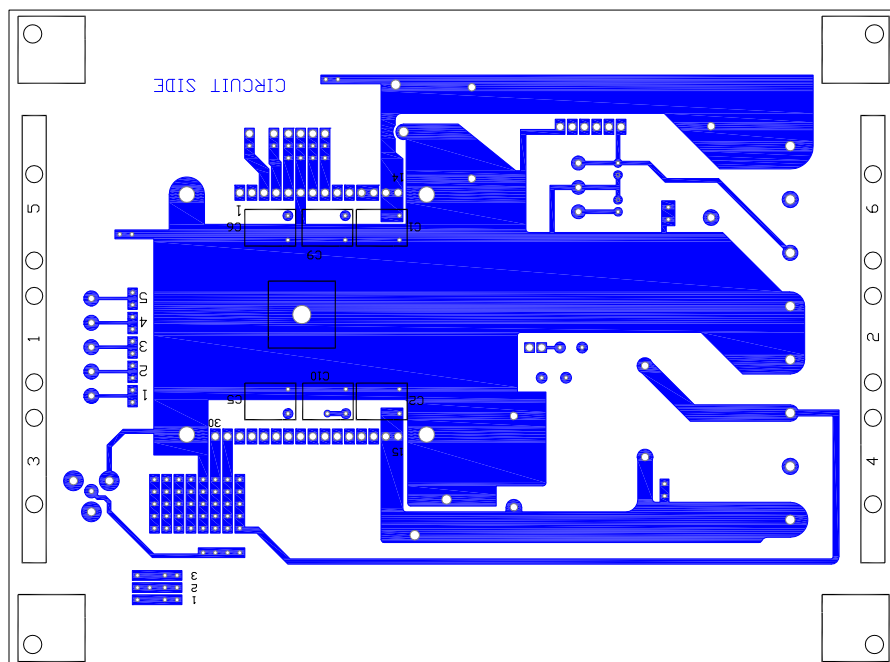

PowerAmp Design ♦ EVAL146 ♦ EVALUATION KIT FOR MODEL PAD146

Assembled EVAL146 with amplifier installed

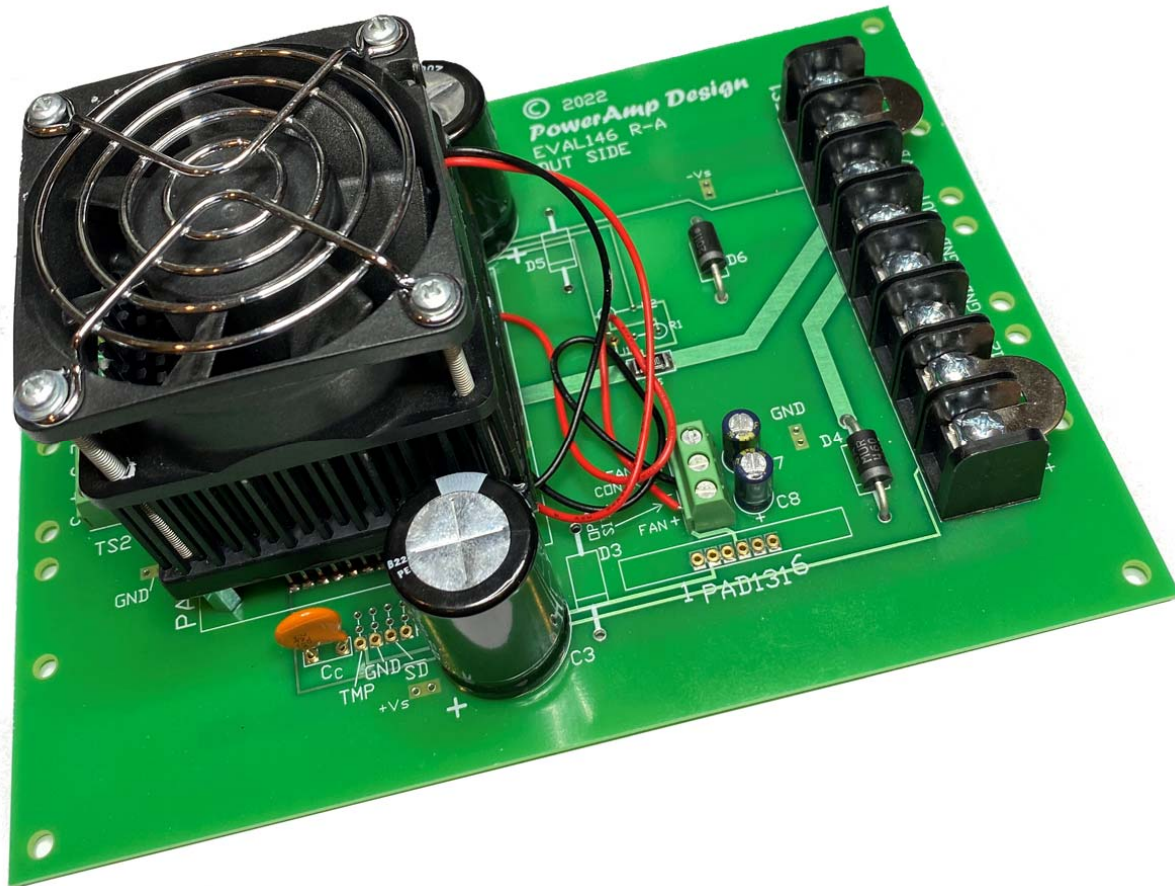

PowerAmp Design ♦ EVAL146 ♦ EVALUATION KIT FOR MODELS PAD146

BOARD OUTLINE DIMENSIONS (IN [mm])

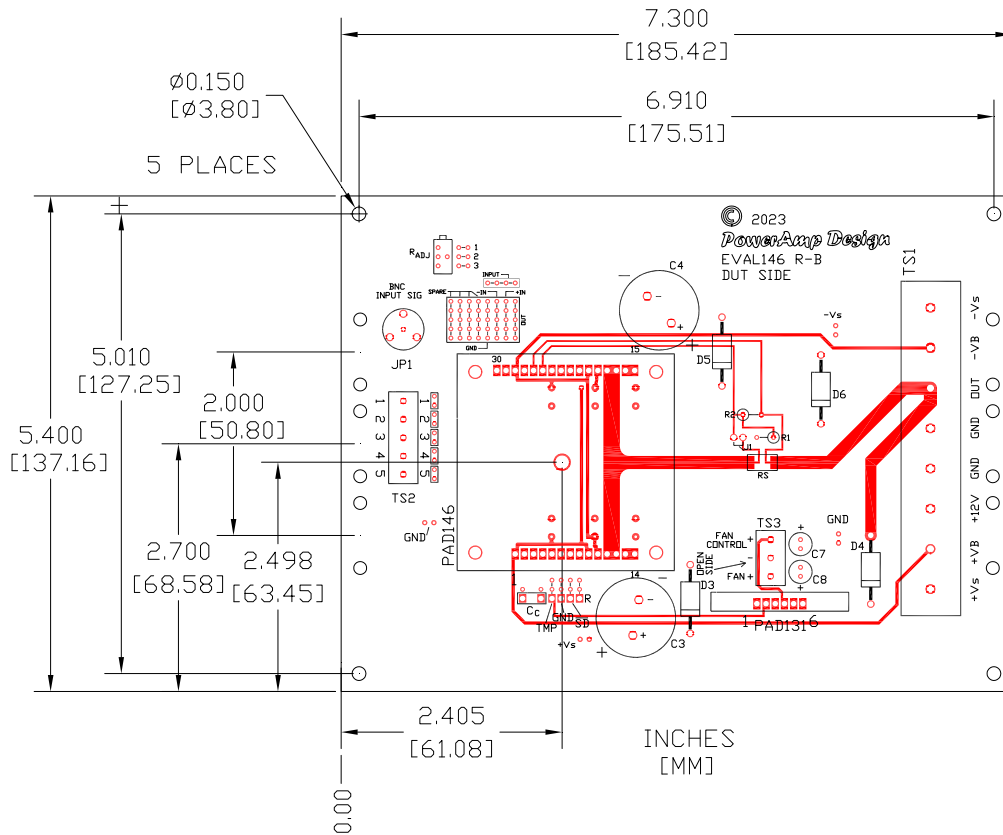

PowerAmp Design ♦ EVAL146 ♦ EVALUATION KIT FOR MODEL PAD146