

PowerAmp Design

CAGE JACK STRIP ACCESSORY COMPONENT

CJS01

Rev C

KEY FEATURES

- SINGLE STRIP OF 32 CAGE JACKS
- EASILY CUT TO LENGTH
- EASY CAGE INSERTION INTO PCB
-  RoHS COMPLIANT

APPLICATIONS

- EVALUATION BOARDS
- MOTHER BOARD ASSEMBLY

DESCRIPTION

The CJS01 is the same cage jack accessory strip used in Power Amp Design evaluation kits like the EVAL118. The 32 cage jack strip simplifies the insertion of the cage jacks into the PCB. The strip can be cut to size easily with wire cutters. The CJS01 is on a 0.1" pitch.

The cage jacks allow for easy insertion and extraction of the amplifier and provide strain relief on the amplifier's pins. The socket's 6 finger contacts are 30 μ " gold plated. Please refer to the Mill-Max part number S703-11-132-47-052000 for further information. Refer also to the application note AN-40.

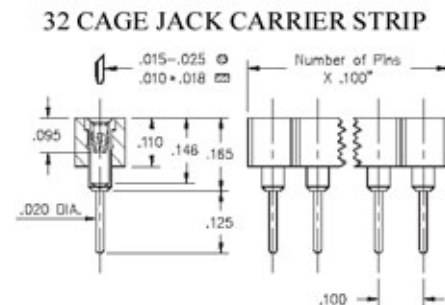
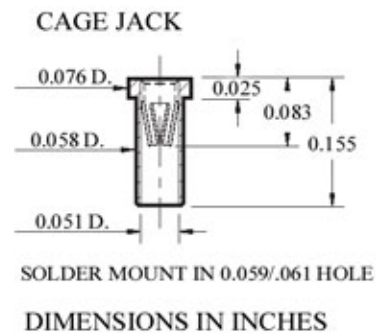
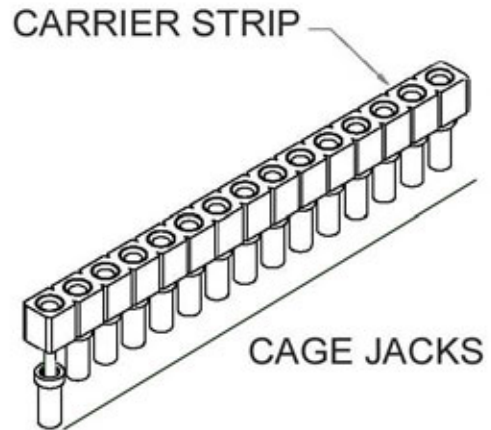

PowerAmp Design ♦ CJS01 ♦ CAGE JACK STRIP ACCESSORY COMPONENT