

PowerAmp Design

COMPACT HIGH VOLTAGE OP AMP

PAD20

Advance Information

Rev B

KEY FEATURES

- LOW COST
- HIGH VOLTAGE – 150 VOLTS
- HIGH OUTPUT CURRENT – 5A
- 40 WATT DISSIPATION CAPABILITY
- 80 WATT OUTPUT CAPABILITY
- INTEGRATED HEAT SINK AND FAN
- SMALL SIZE – 40mm SQUARE

APPLICATIONS

- PIEZO TRANSDUCER DRIVE
- HIGH VOLTAGE INSTRUMENTATION
- SEMICONDUCTOR TESTING

DESCRIPTION

The PAD20 high voltage operational amplifier is constructed with surface mount components to provide a low cost solution for many industrial. With a footprint only 40mm square, similar to the footprint of the TO3 hybrid package, the PAD183 offers outstanding performance that outperforms the more expensive hybrid amplifiers. External compensation tailors the amplifier's response to the application requirements. Four-wire programmable current limit is built-in. The PAD20 also features a substrate temperature reporting output and over-temp shutdown. The amplifier circuitry is built on a thermally conductive but electrically insulating metal substrate mounted to an integrated heat sink and fan assembly. No BeO is used in the PAD20. The PAD20-1 is available without the integrated heat sink and fan for custom applications.



PAD20



PAD20-1



PAD20 INSTALLED IN EVALUATION KIT

A NEW CONCEPT

A critical task in any power amplifier application is cooling the amplifier. Until now component amplifier manufacturers often treated this task as an after-thought, left for the user to figure out. At **Power Amp Design** the best heat sink and fan is chosen at the start and becomes an integral part of the overall amplifier design. The result is the most compact and volumetric efficient design combination at the lowest cost. In addition, this integrated solution concept offers an achievable real-world power dissipation rating, not the ideal rating usually cited when the amplifier case is somehow kept at 25°C. The user no longer needs to specify, procure or assemble separate components.

PowerAmp Design ♦ PAD20 ♦ COMPACT HIGH VOLTAGE OP AMP

EQUIVALENT CIRCUIT

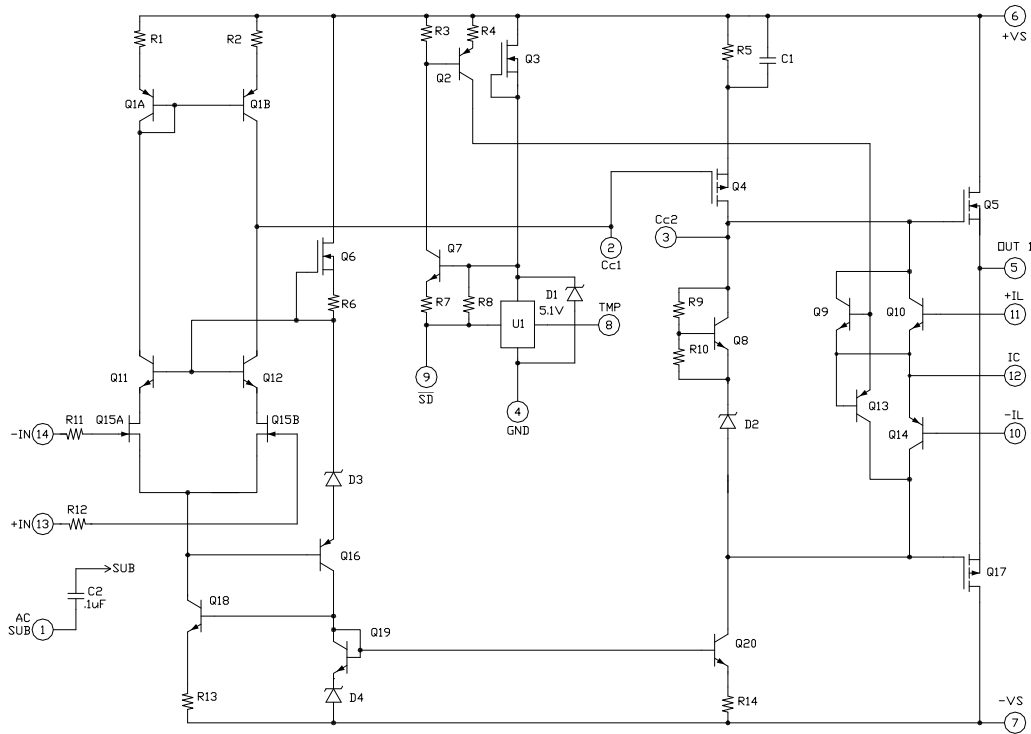

PINOUT & CONNECTIONS

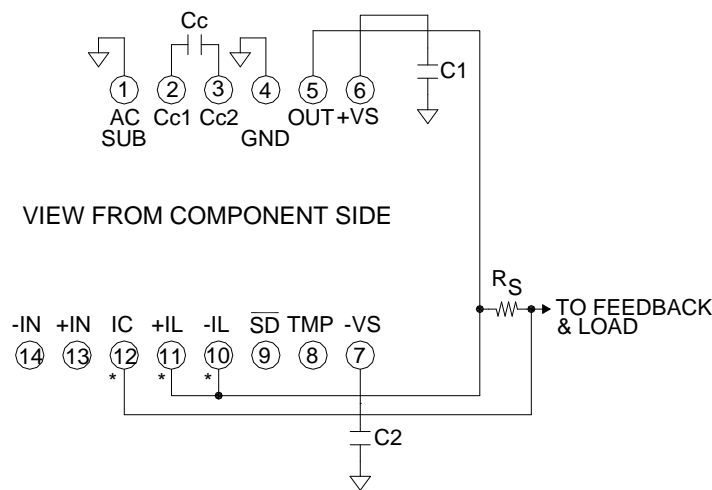

PHASE COMPENSATION SLEW RATE

GAIN	Cc	SLEW RATE
1	150pF	3V/uS
≥ 15	33pF	10V/uS
≥ 50	10pF	20V/uS

* SEE APPLICATION CIRCUITS FOR OTHER CONNECTIONS AND FUNCTIONS.

Power Amp Design ♦ PAD20 ♦ COMPACT HIGH VOLTAGE OP AMP

ABSOLUTE MAXIMUM RATINGS			
SUPPLY VOLTAGE, +Vs to -Vs ⁴	150V	TEMPERATURE, pin solder,	10s, 300°C
SUPPLY VOLTAGE, +Vcc to -Vcc ⁴	150V	TEMPERATURE, junction ²	150°C
INPUT VOLTAGE +Vcc to -Vcc		TEMPERATURE RANGE, storage	-40 to 70°C ⁵
DIFFERENTIAL INPUT VOLTAGE	± 20V	TEMPERATURE RANGE, storage, PAD20-1	105C
OUTPUT CURRENT, peak, within SOA	7A	OPERATING TEMPERATURE, substrate	-40 to 85°C
POWER DISSIPATION, internal, DC	40W		

PARAMETER	TEST CONDITIONS ¹	MIN	TYP	MAX	PAD20-1 ⁹	UNITS
INPUT						
OFFSET VOLTAGE			1	5		mV
OFFSET VOLTAGE vs. temperature	Full temperature range		20	50		μV/°C
OFFSET VOLTAGE vs. supply				20		μV/V
BIAS CURRENT, initial ³				100		pA
BIAS CURRENT vs. supply				0.1		pA/V
OFFSET CURRENT, initial				50		pA
INPUT RESISTANCE, DC			100			G Ω
INPUT CAPACITANCE			4			pF
COMMON MODE VOLTAGE RANGE				+Vs-15		V
COMMON MODE VOLTAGE RANGE				-Vs+8		V
COMMON MODE REJECTION, DC		98	108			dB
NOISE	100kHz bandwidth, 1kΩ R _s		10			μV RMS
GAIN						
OPEN LOOP	R _L = 10kΩ, C _C =10 pF	108				dB
GAIN BANDWIDTH PRODUCT @ 1MHz	C _C =10pF		1			MHz
PHASE MARGIN	Full temperature range	60				degree
OUTPUT						
VOLTAGE SWING	I _O = 5A	+Vs-7	+Vs-6			V
VOLTAGE SWING	I _O = -5A	-Vs+7	-Vs+6			V
CURRENT, continuous, DC				5		A
SLEW RATE, A _v = +50	C _C = 10pF	5				V/μS
SETTLING TIME, to 0.1%	2V Step, C _C = 10pF		4			μS
RESISTANCE	No load, DC		8			Ω
POWER SUPPLY						
VOLTAGE		± 15	± 60	± 75		V
CURRENT, quiescent			6	8		mA
THERMAL						
RESISTANCE, AC, junction to air or case ⁶	Full temperature range, f ≥ 60Hz			2.1 to air	1.7 to case	°C/W
RESISTANCE, DC junction to air or case	Full temperature range			3.1 to air	2.5 to case	°C/W
TEMPERATURE RANGE, substrate		-40		85	85	°C
TEMPERATURE RANGE, ambient ⁵		-40		70	NA	°C
FAN, 40mm dc brushless, ball bearing						
OPERATING VOLTAGE			12		NA	V
OPERATING CURRENT			50		NA	mA
AIR FLOW			7.5		NA	CFM
RPM			7000		NA	RPM
NOISE			30		NA	dB
L10, life expectancy, 50°C ⁸			45		NA	kHrs
L10, life expectancy, 25°C ⁸			60		NA	kHrs

NOTES:

1. Unless otherwise noted: T_C = 25°C, compensation C_c = 47pF, DC input specifications are ± value given, power supply voltage is typical rating.

2. Derate internal power dissipation to achieve high MTBF.

3. Doubles for every 10°C of case temperature increase.

4. +Vs and -Vs denote the positive and negative supply voltages to the output stage. +Vcc and -Vcc denote the positive and negative supply voltages to the small signal stages. +Vcc and -Vcc may not be more than + and - 20V greater than +Vs and -Vs respectively.

5. Limited by fan characteristics. During operation, even though the heat sink may be at 85°C the fan will be at a lower temperature.

6. Rating applies if the output current alternates between both output transistors at a rate faster than 60Hz.

7. Power supply voltages +Vcc and -Vcc must not be less than +Vs and -Vs respectively. Total voltage +Vcc to -Vcc 190V maximum.

8. L10 refers to the time it takes for 10% of a population of fans to fail. Lower ambient temperature increases fan life.

9. Specifications for the PAD20-1 are the same as for the PAD20 except as shown in this column.

COOLING FAN

The PAD20 relies on its fan for proper cooling of the amplifier. Make sure that air flow to the fan and away from the heat sink remains unobstructed. The cooling method used is impingement cooling, which means that cool air is pushed into the heat sink and warm air is exhausted through the spaces between the heat sink fins.

CURRENT LIMIT

The current limiting function of the PAD20 is a versatile circuit that can be used to implement a four-wire current limit configuration or, in combination with some external components can be configured to implement a fold-over current limit circuit. The four-wire current limit configuration insures that parasitic resistance in the output line, R_p , does not affect the programmed current limit setting. See Figure 1. The sense voltage for current limit is 0.63V. Thus approximately:

$$I_L = \frac{0.63V}{R_S}$$

Where I_L is the value of the limited current and R_S is the value of the current limit sense resistor from 0.4 Ω -40 Ω . See graph for Current Limit Value vs R_S .

In addition, the sense voltage has a temperature coefficient approximately equal to $-2.2\text{mV}/^\circ\text{C}$. The fold-over function reduces the available current as the voltage across the output transistors increases to help insure that the SOA of the output transistors is not exceeded. Refer to Figure 5 in **Application Circuits** for details on how to connect the current limit circuitry to implement either a four-wire current limit or current limit with a fold-over function.

In some applications better current limiting protection and a lower sense voltage may be desired. In this case the PAD20 can be operated with the PAD123 current limit accessory module. See Figure 4 in the applications section and the PAD123 data-sheet for more details.

MOUNTING THE PAD20

The amplifier is supplied with four 4-40 M/F hex spacers at the four corners of the amplifier. Once the amplifier is seated, secure the module with the provided 4-40 nuts and torque to 4.7 in oz [3.8 N cm] max. See “**Dimensional Information**” for a detailed drawing. It is recommended that the heat sink be grounded to the system ground. This can easily be done by providing a grounded circuit board pad around any of the holes for the mounting studs.

MOUNTING THE PAD20-1 AMPLIFIER

In most applications the amplifier must be attached to a heat sink. Spread a thin and even coat of heat sink grease across the back of the PAD20-1 and also the heat sink where the amplifier is to be mounted. Push the amplifier into the heat sink grease on the heat sink while slightly twisting the amplifier back and forth a few times to bed the amplifier into the heat sink grease. On the final twist align the mounting holes of the amplifier with the mounting holes in the heat sink and finish the

mounting using 4-40 hex male-female spacers and torque to 4.7 in oz [3.8 N cm] max. Mount the amplifier to the mother board with 4-40 X 1/4” screws. See Dimensional Information for additional recommendations.

TEMPERATURE REPORTING

An analog output voltage is provided (pin 8, TMP) relative to ground and proportional to the temperature in degrees C. The slope is approximately $-10.82\text{mV}/^\circ\text{C}$. The output voltage follows the equation:

$$T = (2.127 - V) (92.42)$$

Where V is the TMP output voltage and T is the substrate temperature in degrees C.

This high impedance output circuit is susceptible to capacitive loading and pickup from the output of the amplifier.

THERMAL SHUTDOWN

The temperature monitoring circuit automatically turns off the amplifier when the substrate temperature reaches 110°C . When the substrate cools down 10°C the amplifier is enabled once again. The thermal shutdown feature is activated either by amplifier overloads or a failure of the fan circuit.

EXTERNAL SHUTDOWN

When pin 9 (\overline{SD}) is taken low (ground) the amplifier is turned “off” and remains “off” as long as pin 9 is low. When pin 9 is monitored with a high impedance circuit it also functions as a flag, reporting when the amplifier is shut down. A “high” (+5V) on pin 9 indicates the temperature is in the normal range. A “low” (ground) indicates a shutdown condition. See **Application Circuits** Figure 2 for details on how to implement an external shutdown circuit and how to monitor the shutdown status when temperature is in the normal range. A “low” (ground) indicates a shutdown condition. See **Application Circuits** for details on how to implement an external shutdown circuit and how to monitor the shutdown status.

PHASE COMPENSATION

The PAD20 **must** be phase compensated. The compensation capacitor, C_C , is connected between pins 2 and 3. The compensation capacitor must be an NPO type capacitor rated for the full supply voltage (150V). On page 2, under Amplifier Pinout and Connections, you will find a table that gives recommended compensation capacitance value for various circuit gains and the resulting slew rate for each capacitor value. Consult also the small signal response and phase response plots for the selected compensation value in the Typical Performance Graphs section. A compensation capacitor less than 10pF is not recommended.

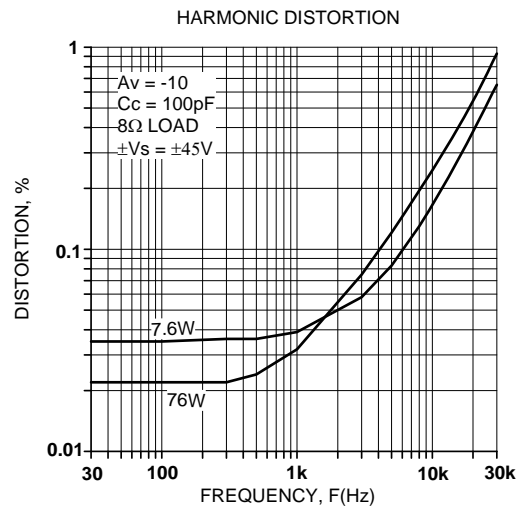
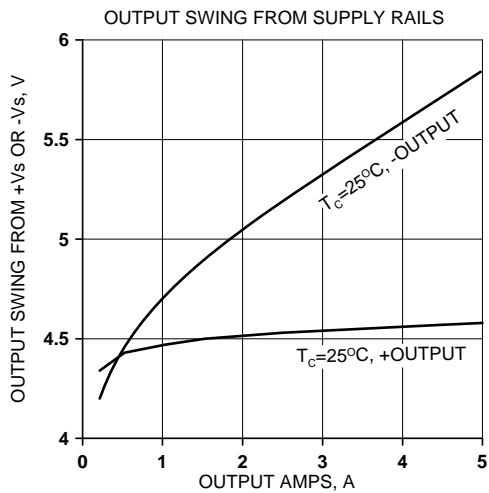
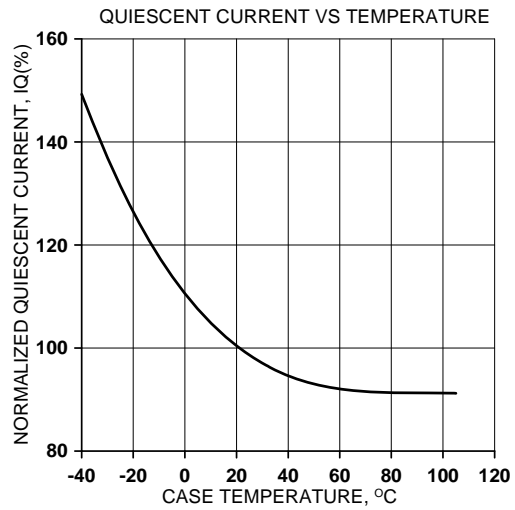
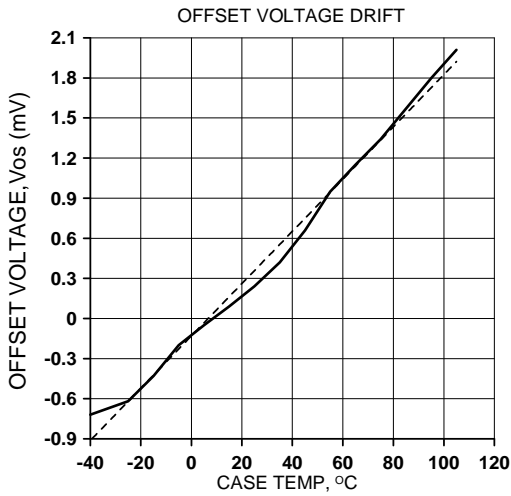
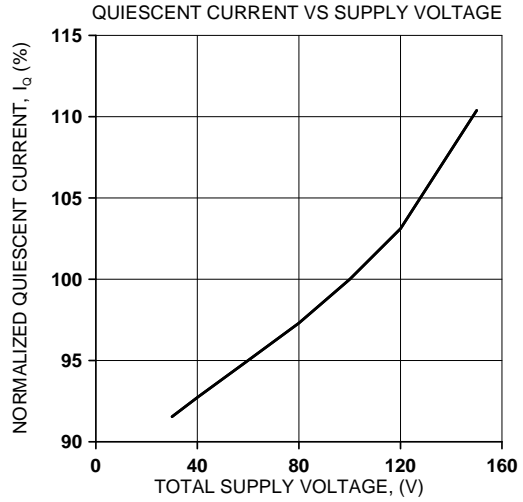
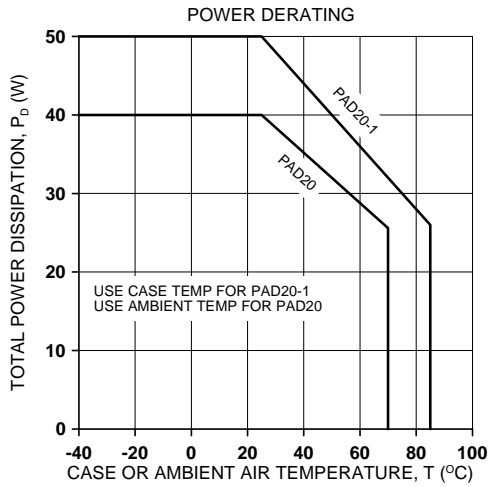

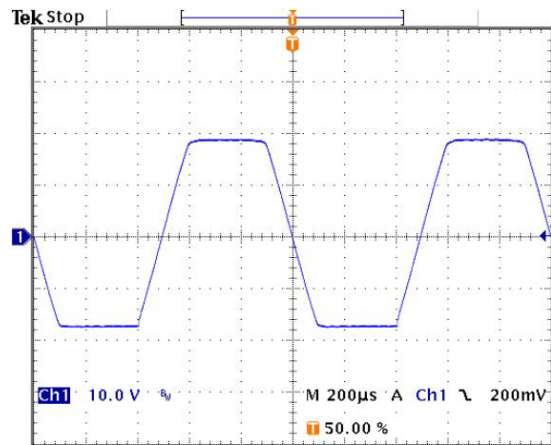
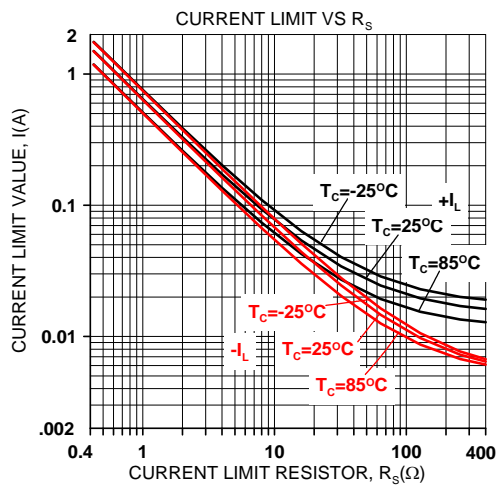
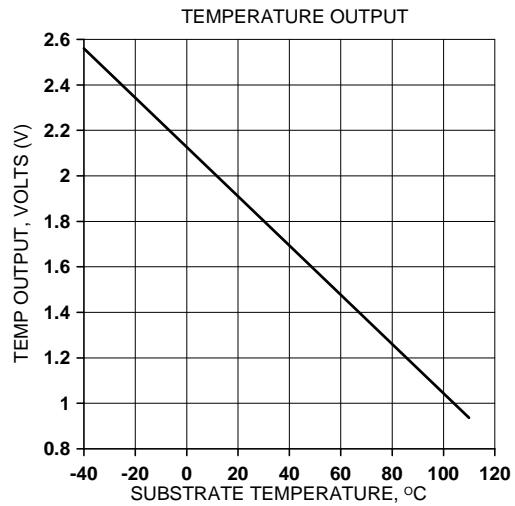
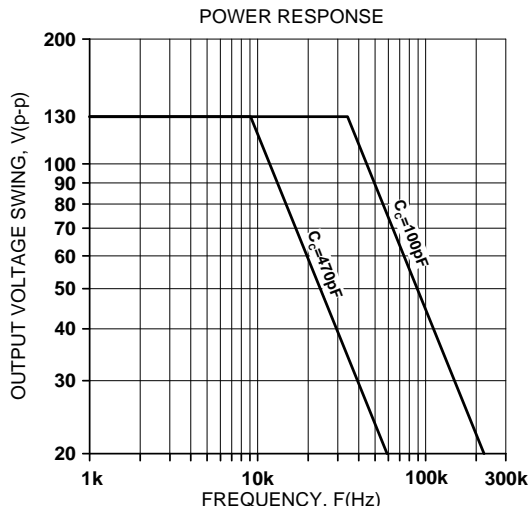
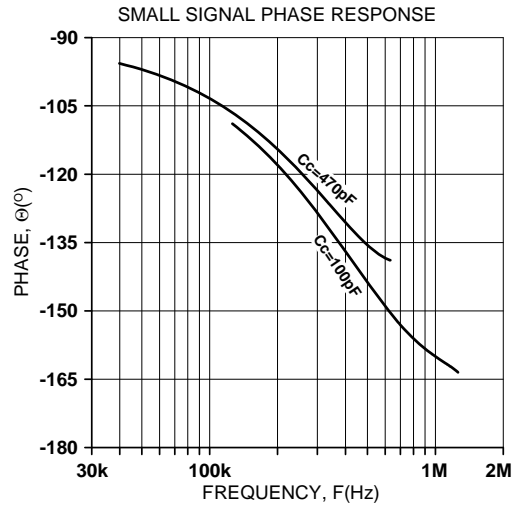
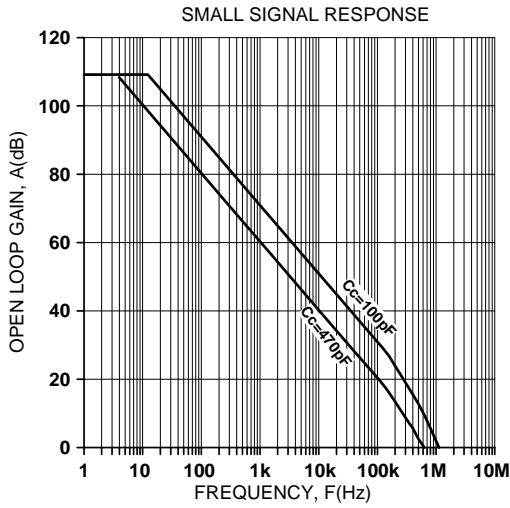

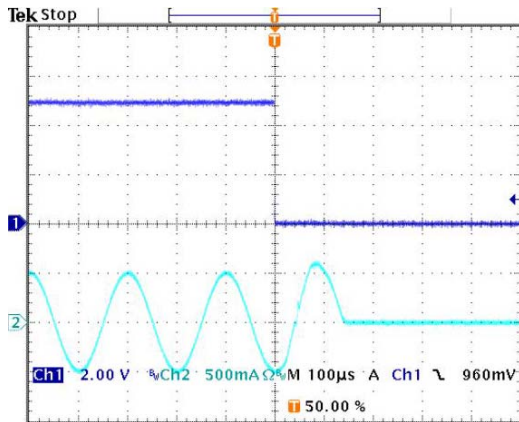

SHUTDOWN RESPONSE, NEGATIVE OUTPUT TO ZERO TRANSITION

The oscilloscope display at the left shows a view of a 5kHz, 1A p-p amplifier output signal being interrupted near the negative peak by a shutdown signal on Ch1. The Ch2 display shows the output *current* going to zero about 150μS after the shutdown signal goes low.

SHUTDOWN RESPONSE, POSITIVE OUTPUT TO ZERO TRANSITION

The oscilloscope display at the right shows a view of a 5kHz, 1A p-p amplifier output signal being interrupted near the positive peak by a shutdown signal on Ch1. The Ch2 display shows the output *current* going to zero about 50μS after the shutdown signal goes low.

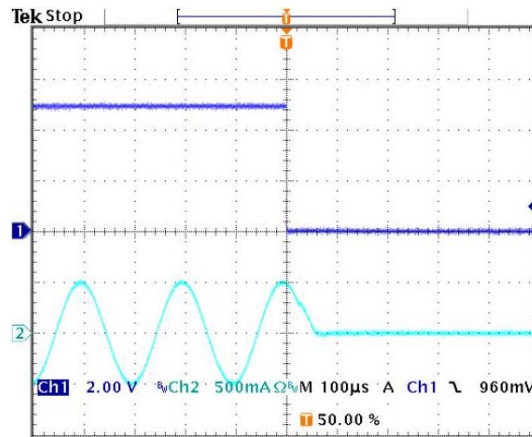

SHUTDOWN RECOVERY

The oscilloscope display at the left shows a view of a 5kHz, 1A p-p amplifier output signal on Ch2 resuming normal operation after a shutdown signal on Ch1 go high (not shutdown). The output signal resumes normal operation after a delay of about 1mS.

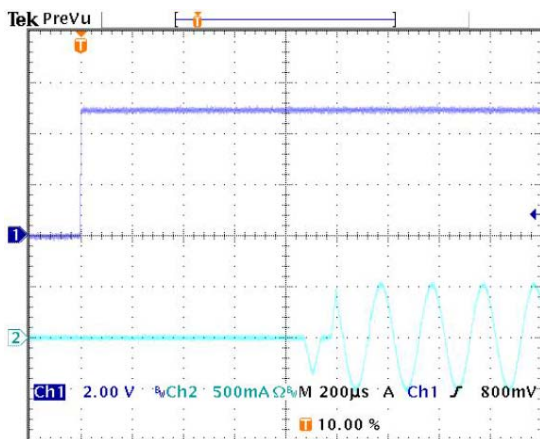

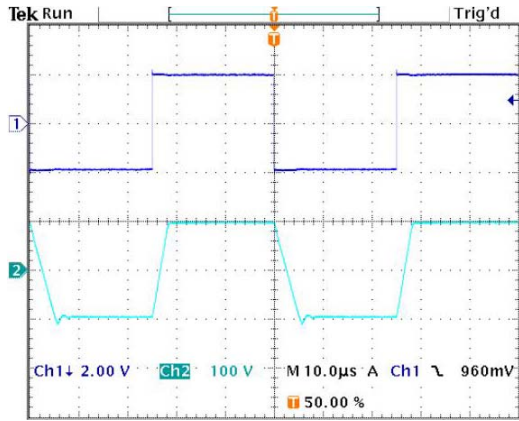

Pulse Response, 20kHz, 200Vp-p
G=-50, Cc=10pF

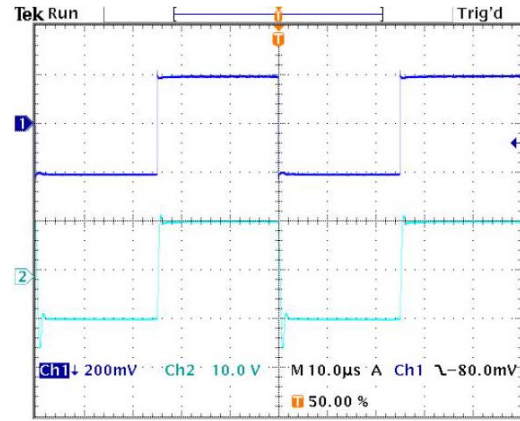

Pulse Response, 20kHz, 20Vp-p
G=-50, Cc=10pF

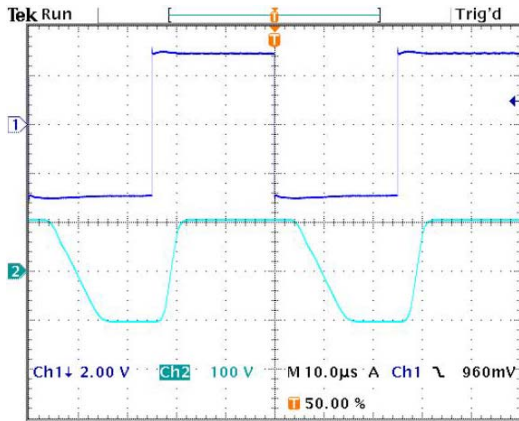

Pulse Response, Overloaded Input, 20kHz, 200Vp-p
G=-50, Cc=10pF

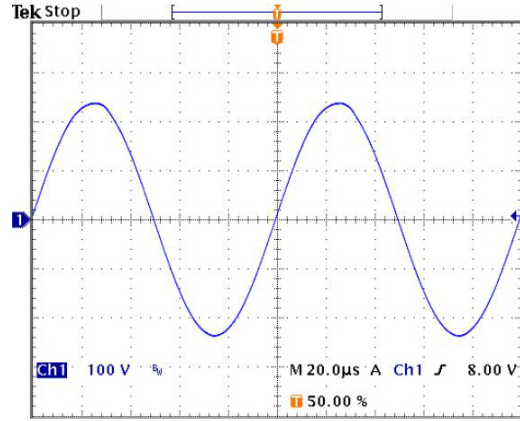

10kHz sine into 250Ω load, G=-50, Cc=10pF

Power Amp Design ♦ PAD20 ♦ COMPACT HIGH VOLTAGE OP AMP

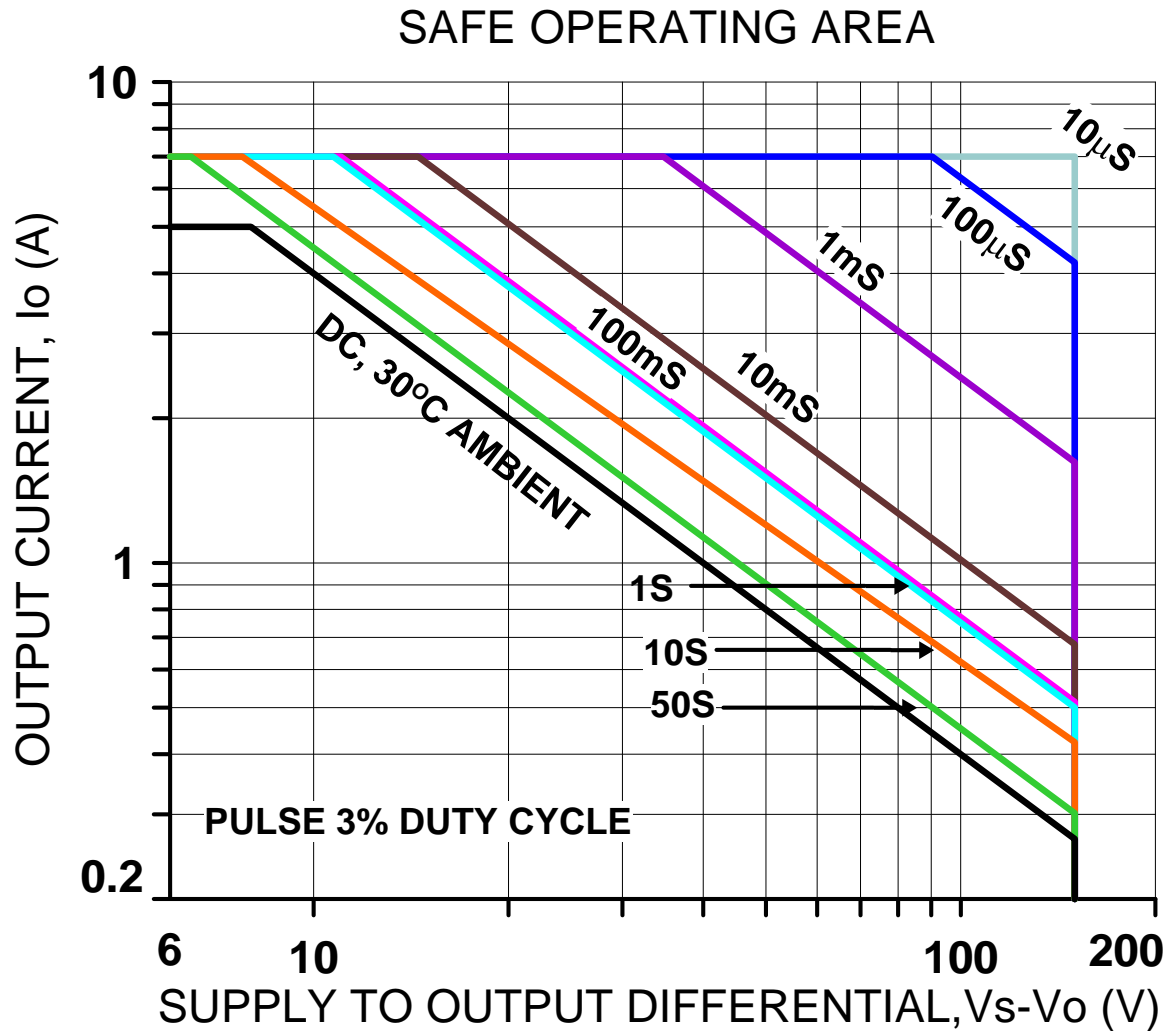

SAFE OPERATING AREA

The safe operating area (SOA) of a power amplifier is its single most important specification. The SOA graph presented above serves as a first approximation to help you decide if the PAD20 will meet the demands of your application. But a more accurate determination can be reached by making use of the **PAD Power™** spreadsheet which can be found in the *Power Amp Design* website under the *Design Spreadsheet* tab. While the graph above adequately shows DC SOA and some pulse information it does not take into account ambient temperatures higher than 30°C, AC sine, phase or non-symmetric conditions that often appear in real-world applications. The **PAD Power™** spreadsheet takes all of these effects into account.

PowerAmp Design ♦ PAD20 ♦ COMPACT HIGH VOLTAGE OP AMP

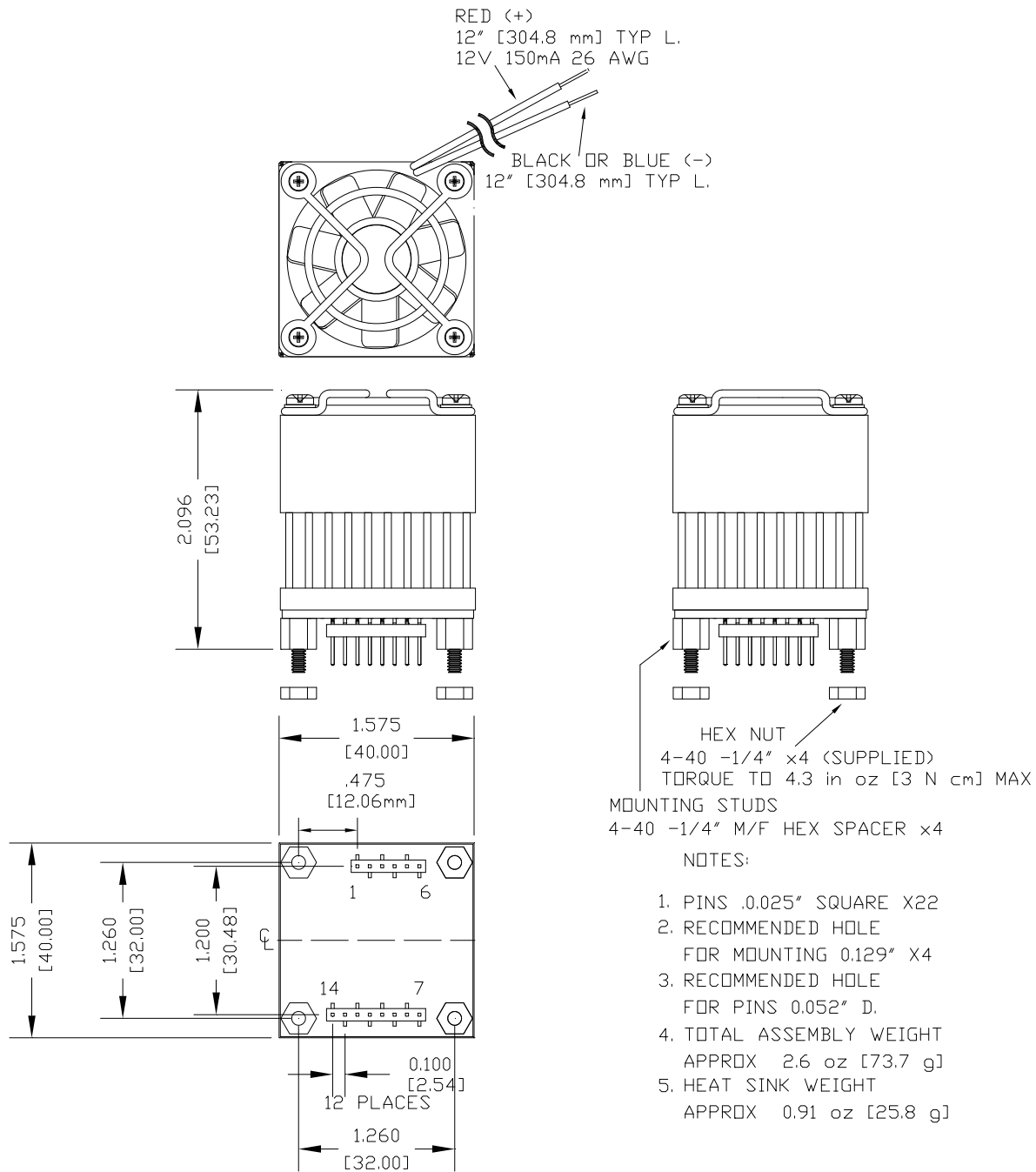

PowerAmp Design ♦ PAD20 ♦ COMPACT HIGH VOLTAGE OP AMP

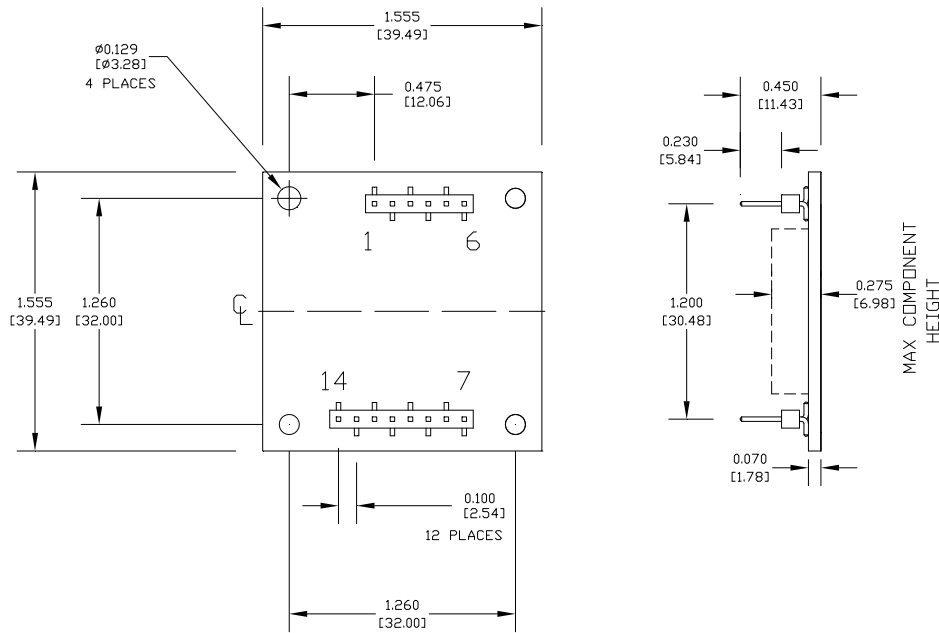

- NOTES: 1: DIMENSIONS ARE INCHES, [mm]
 2: PINS 0.025" SQUARE [0.635mm], GOLD PLATED
 3: RECOMMENDED HOLE FOR MOUNTING 0.129" D. x2 [3.277mm]
 4: RECOMMENDED HOLE FOR PINS 0.052" D. [1.321mm]
 5: HIGHLY RECOMMENDED THAT AMPLIFIER IS MOUNTED INTO CAGE JACKS USING PAD PART NUMBER CJS01. USE 0.062" [1.575mm] HOLE FOR CAGE JACKS.
 6: HIGHLY RECOMMENDED THAT AMPLIFIER IS MOUNTED INTO HEAT SINK WITH 4-40 M/F SPACERS TO PROVIDE STRAIN RELIEF FOR PINS. SEE DRAWING BELOW.

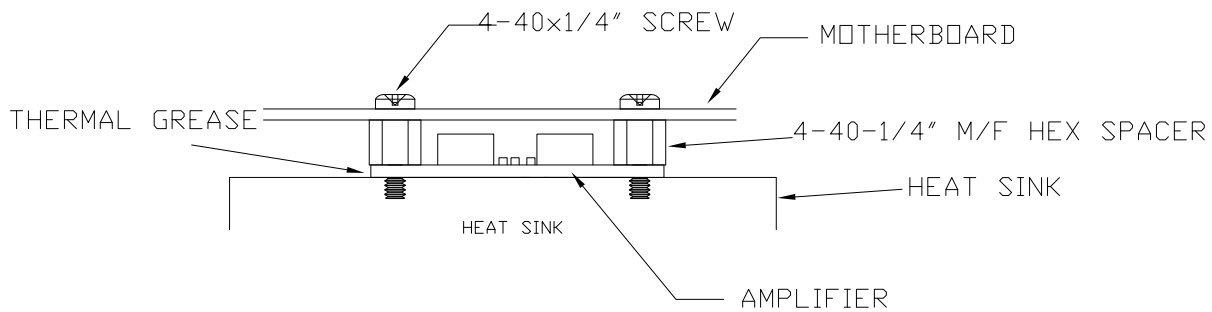

PAD20-1

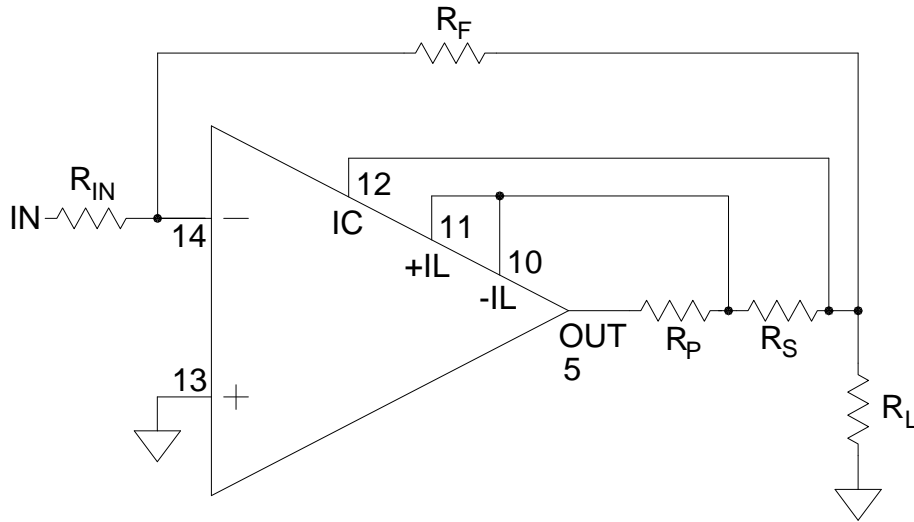

FIGURE 1.
4-WIRE CURRENT LIMIT

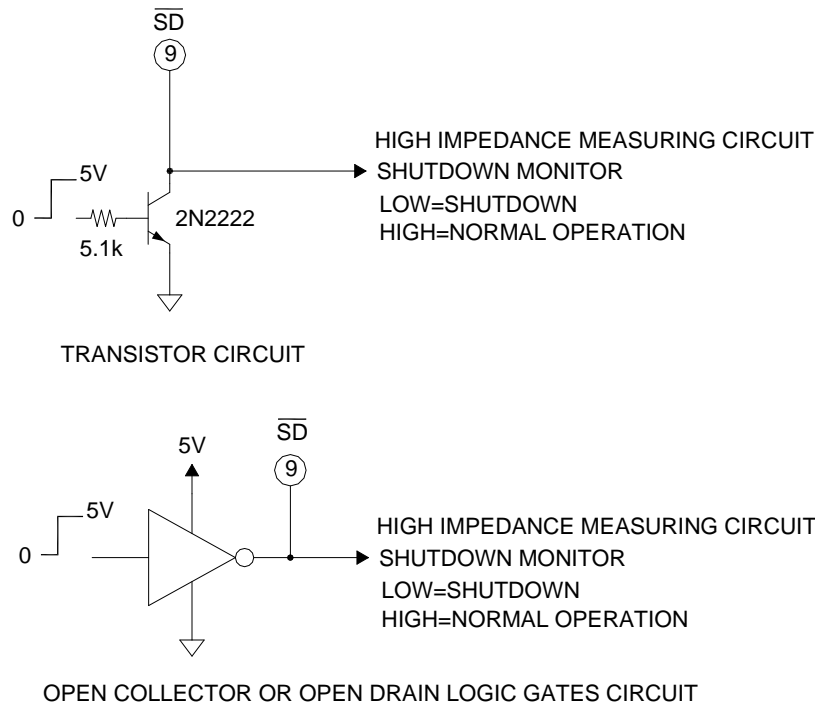

FIGURE 2.
EXTERNAL SHUTDOWN WITH MONITOR

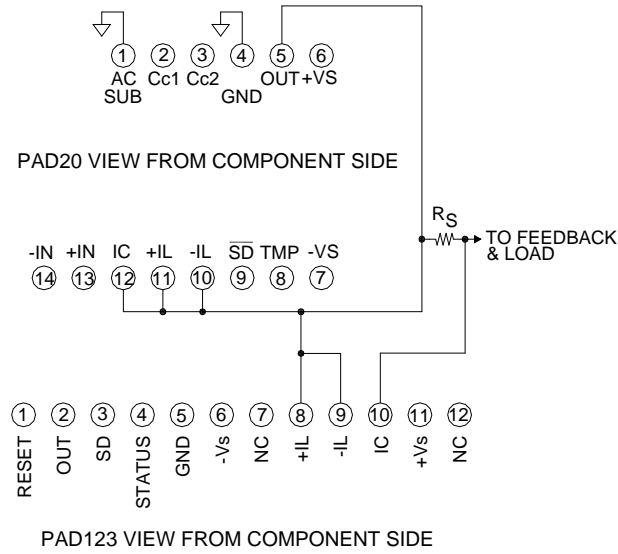

FIGURE 3
TYPICAL CONNECTIONS TO PAD123 CURRENT LIMIT ACCESSORY MODULE

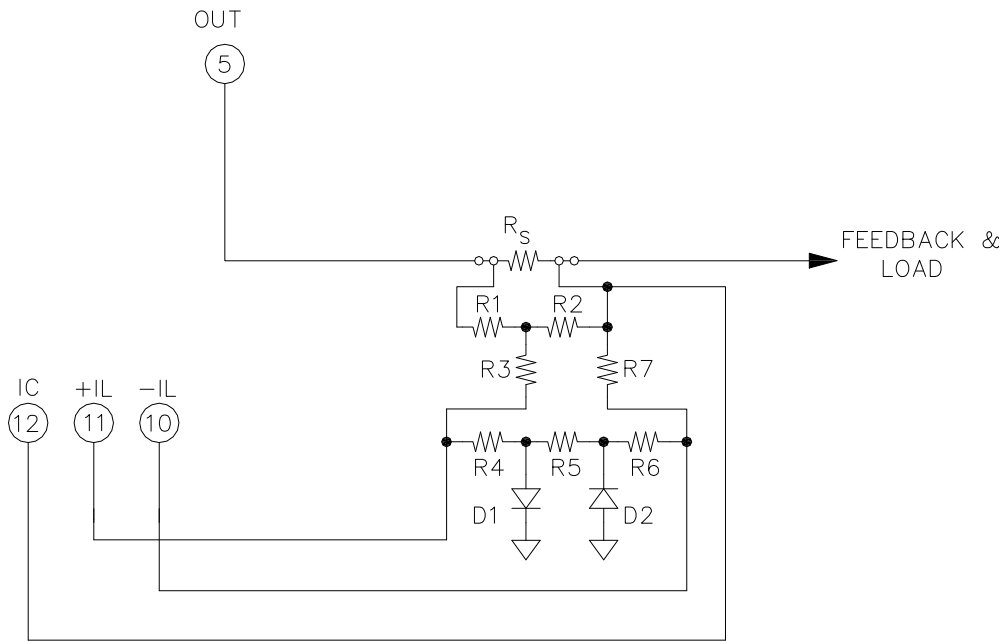

FIGURE 5
DUAL SLOPE (FOLD-OVER) CURRENT LIMIT

With the three current limit function pins (pins 10-12) dual slope current limiting can be implemented that more closely approximates the SOA curve of the amplifier than can be achieved with standard current limiting techniques. Values for resistors R1-R7 and R_s can be calculated using the **PAD Power**™ Excel spreadsheet that can be downloaded from the Power Amp Design web site under the *Design Spreadsheet tab*.