

AN-10

The Rail to Rail Advantage

Author: Dennis Eddlemon, Power Amp Design

Rev. March 14, 2006

Synopsis: Examples are given to illustrate the technical advantages for a power operational amplifier whose output voltage can closely approach the power supply voltages both for dual and single supply applications. Supporting calculations are given using a dedicated spreadsheet that can be downloaded from the internet.

In recent years the small-signal monolithic rail to rail input, rail to rail output, operational amplifier has become a mainstay in the arsenal of several manufacturers' amplifier lines. These op amps go by the moniker of *RRIO op amps* and are usually powered by 5 volts. They can be operated with the inputs biased to either supply rail and the outputs can approximate the power supply rails with light loading (micro-amps to a few milliamps). The impetus for this kind of design is simple enough: in many applications the few volts of available supply voltage needs to result in the largest possible output signal amplitude and not squandered on "drop from the rail" that reduces the maximum peak to peak output signal that conventional op amp designs exhibit. The RRIO design can produce almost $5V_{P-P}$ of usable output signal with only a 5V supply. Also, with an input common mode range capable of reaching the negative supply rail (ground, most often) the amplifier can be operated with a single (5V) supply.

In the world of power op amps things are a little different. Power op amps usually operate with much higher supply voltages, far more output current and can deliver tens or hundreds of watts to a load. The impetus to design a RRIO power op amp is similar even though the supply voltages and output currents are far greater than with its monolithic cousins.

For a RRIO power op amp efficiency is the prime design motivator. Even when power supply voltages are far higher than 5V the ability for the output to swing very close to the supply voltage is important. Let's look at an example of the advantage of the model PAD117 RRIO power op amp from Power Amp Design vs. a conventional power op amp design. Consider Figure 1 below. To calculate critical parameters such as the amplifier's

output transistor junction temperature and the amplifier's case temperature we will use Power Amp Design's **PAD Power** spreadsheet available for download from its website: <http://www.PowerAmpDesign.net> under the **Power Tools** tab.

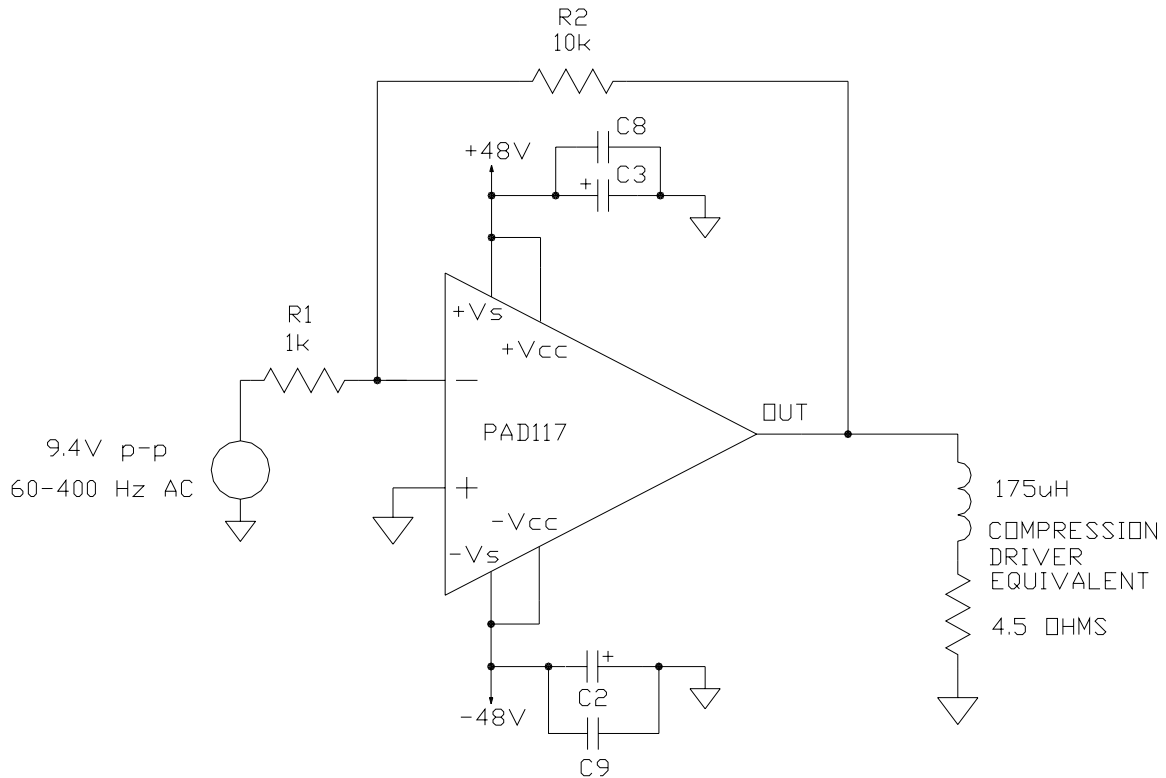

Figure 1.

Load: compression driver, 4.5Ω, 175μH, operating @ 60-400Hz

Supply: ±48V

Full output: 94V_{P-P}. (+47V to -47V, only 1V from each supply rail required to produce 10.4A peak into the load)

Ambient temperature: 30°C

Using the **PAD Power** spreadsheet we find that:

Output amps peak=10.4A

Output V_{RMS}=33.2V

Amplifier case temperature=83.7°C

Maximum output transistor temperature=126.4°C

Amplifier dissipates 103.7W_{RMS}

Amplifier delivers 245.4W_{RMS} to the load

For another amplifier without rail to rail output capability (but otherwise equal to the PAD117) the internal biasing necessary to operate the output transistor will typically require a 6V drop from the rail to deliver 10.4A to the load. To get the same 94V_{P-P} voltage to the transducer the supply voltage necessary is ±53V (47V_{peak} + 6V from each power supply rail). With the same output volts and amps to the load the conventional amplifier design will now need to tolerate:

Amplifier case temperature=95.3°C

Maximum output transistor temperature=147.3°C

Amplifier dissipates 126.5W_{RMS}

The following table summarizes the analysis results:

Amplifier Design	Case Temp	Amp Dissipation	Junction Temp	Output
RRIO	83.7°C	103.7W	126.4°C	245.4W
Conventional	95.3°C	126.5W	147.3°C	245.4W

From this example we can see that while the PAD117 RRIO op amp operates comfortably with this load. A similar design without rail to rail output operation operates at noticeably higher output transistor junction temperature and amplifier case temperature due the lower operating efficiency. Using the data from the table we can calculate that the conventional amplifier design dissipates 22% more power while delivering the same output power.

This example was constructed to illustrate the efficiency advantage of a RRIO amplifier, but also other points as well: You will not find a commercial power op amp capable of a case temperature 95°C or a 100V amplifier that is allowed to operate on ±53V (106 V total). To solve the first problem you would need to purchase a military grade amplifier so that a 95°C case temperature is permitted. To solve the second problem you would need to find an amplifier rated at more than 100V of total supply voltage (200V is the next rating step). Both of these solutions are much more expensive. For cost reasons the only practical solution is to lower the power supply voltages so that the operating voltage of the amplifier will not be exceeded. Additionally, the power supply voltage must be reduced enough to bring down the amplifier case temperature to a commercial rating of 85°C

or less. Lowering the power supply voltages also lowers the power that can be delivered to the load.

In this example reducing the power supply voltages from $\pm 53\text{V}$ to $\pm 48\text{V}$ and reducing the output signal solves the problem. Again, using the **PAD Power** spreadsheet, the operating parameters are:

- Ambient temperature: 30°C
- Supply: $\pm 48\text{V}$
- Full output: $88\text{V}_{\text{p-p}}$
- Output amps peak = 9.8A
- Output $V_{\text{RMS}}=31.1\text{V}$
- Amplifier case temperature= 83.7°C
- Maximum output transistor temperature= 126.4°C
- Amplifier dissipates $103.7\text{W}_{\text{RMS}}$
- Amplifier delivers $215.1\text{W}_{\text{RMS}}$ to the transducer

The following table summarizes the performance of the RRIO amplifier design and the modified conventional amplifier design:

Amplifier Design	Case Temp	Amp Dissipation	Junction Temp	Output
RRIO	83.7°C	103.7W	126.4°C	245.4W
Conventional	83.7°C	103.7W	126.4°C	215.1W

In this example while the PAD117 RRIO op amp can deliver $245.4\text{W}_{\text{RMS}}$ to the load a conventional amplifier design under the same conditions can only deliver $215.1\text{W}_{\text{RMS}}$ to the load. Stated another way, under these conditions the PAD117 can deliver 14.1% more power to the load while dissipating the same power as a conventional amplifier design.

It's important to further note that as the power supply voltage decreases the relative advantage of the RRIO amplifier increases. This is simply because as the power supply voltage decreases the voltage drop from the rail of the conventional design increases much more rapidly as a proportion of the available voltage from the power supply than with the RRIO design.

Figure 2 shows one way to take full advantage of the RRIO amplifier by using its rail to rail features at both the input and output of the amplifier. In the example only one 36V power supply is required. E1 generates the peak to peak signal that will be gained a factor of 10 by the amplifier. E2 provides

an offset of +17.5V so that the output of the amplifier will swing symmetrically from +35 to 0 volts at its output.

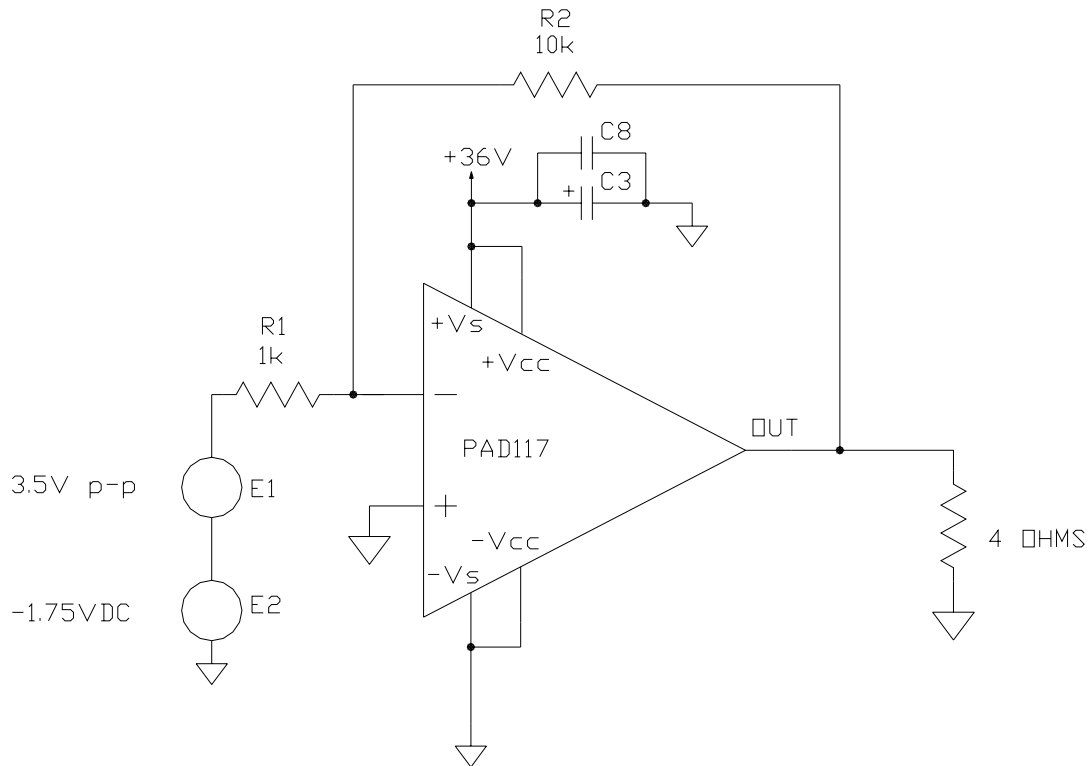

Figure 2.

It is, of course, possible to operate a conventionally designed power op amp with one power supply. Since the power supply is the single most expensive component in an application circuit (other than the amplifier and load device) operating with only one power supply is a considerable economic advantage. But compared to a conventional op amp design the RRIO amplifier has two significant additional advantages in this circuit. As shown in the first example the output of the RRIO amplifier can swing much closer to the supply voltage than the conventional amplifier. But, in addition, the RRIO amplifier can actually reach zero volts at its output when there is no current in the load. A conventional amplifier design cannot reach zero output volts even when there is no load current. A typical no-load output voltage for the conventional amplifier operated with a single supply is about 2-5V. With a single 36V supply the PADS117 can achieve a 35V_{p-p} into the load. A conventional amplifier could only achieve about 25-28 V_{p-p}. In addition, the PADS117 has a common mode voltage range that includes ground for single supply applications. The non-inverting input can be grounded, thus avoiding

a messy biasing scheme that the conventional amplifier design would require to bias its non-inverting input at some voltage above ground (usually in the range of 5-15V).

The advantages of the rail to rail amplifier, then, are many. The ability to operate on a single supply saves the cost of an additional power supply (and the cost and space of the associated by-pass capacitors). The operating efficiency is significantly higher due to its low voltage drop from the supply rail. That efficiency also results in lower operating costs and lower amplifier operating temperatures that enhance reliability. And its ability to operate with a common mode input voltage to ground with single supply operation aids in the design of simple input circuits.