

PowerAmp Design

COMPACT HIGH VOLTAGE OP AMP

PAD183

Rev B

KEY FEATURES

- LOW COST
- SMALL SIZE 40mm SQUARE
- HIGH VOLTAGE – 350 VOLTS
- HIGH OUTPUT CURRENT – 1.5A
- 35 WATT DISSIPATION CAPABILITY
- 100kHz POWER BANDWIDTH 330Vp-p
- 100V/ μ S SLEW RATE

APPLICATIONS

- HIGH VOLTAGE INSTRUMENTATION
- ELECTROSTATIC TRANSDUCERS
- ELECTROSTATIC DEFLECTION
- PIEZO TRANSDUCER DRIVE

DESCRIPTION

The PAD183 high voltage operational amplifier is constructed with surface mount components to provide a low cost solution for many industrial applications. With a footprint only 40mm square, similar to the footprint of the TO3 hybrid package, the PAD183 offers outstanding performance that outperforms the more expensive hybrid amplifiers. Integrated heat sink and fan cooling is included. User selectable external compensation tailors the amplifier's response to application requirements. The PAD183 is built on a thermally conductive but electrically insulating metal substrate. No BeO is used in the PAD183. For custom applications the PAD183-1 is available without the integrated heat sink and fan cooling.



PAD183



PAD183-1



PAD183 MOUNTED IN EVAL135 EVALUATION KIT

A NEW CONCEPT

A critical task in any power amplifier application is cooling the amplifier. Until now component amplifier manufacturers often treated this task as an after-thought, left for the user to figure out. At **Power Amp Design** the best heat sink and fan is chosen at the start and becomes an integral part of the overall amplifier design. The result is the most compact and volumetric efficient design combination at the lowest cost. In addition, this integrated solution concept offers an achievable real-world power dissipation rating, not the ideal rating usually cited when the amplifier case is somehow kept at 25°C. The user no longer needs to specify, procure or assemble separate components.

PowerAmp Design ♦ PAD183 ♦ COMPACT HIGH VOLTAGE OP AMP

EQUIVALENT CIRCUIT

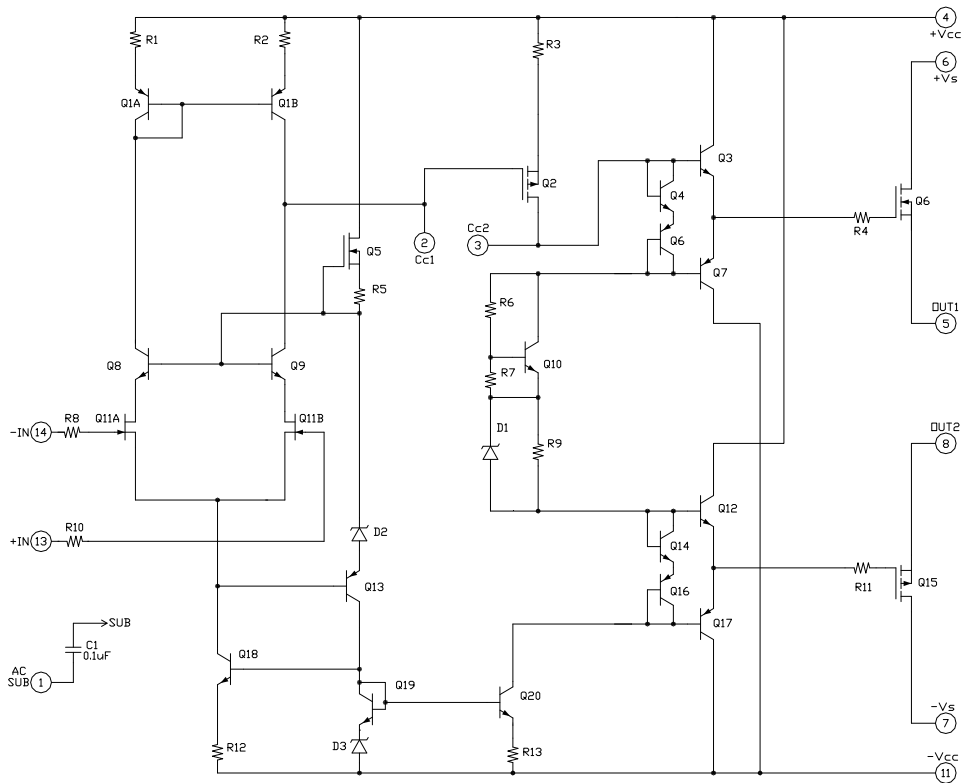

PINOUT & CONNECTIONS

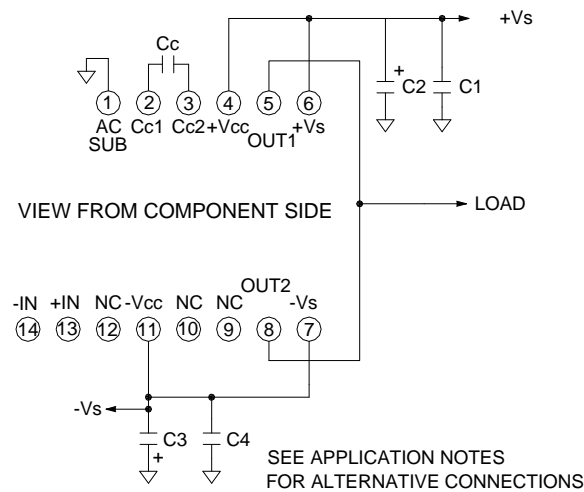

PHASE COMPENSATION		SLEW RATE
GAIN	Cc	
1	150pF	15V/uS
2	47pF	50V/uS
≥ 4	22pF	100V/uS

Power Amp Design ♦ PAD183 ♦ COMPACT HIGH VOLTAGE OP AMP

ABSOLUTE MAXIMUM RATINGS			
SUPPLY VOLTAGE, +Vs to -Vs ⁴	350V	TEMPERATURE, pin solder,	10s, 300°C
SUPPLY VOLTAGE, +Vcc to -Vcc ⁴	350V	TEMPERATURE, junction ²	150°C
INPUT VOLTAGE +Vcc to -Vcc		TEMPERATURE RANGE, storage	-40 to 70°C ⁵
DIFFERENTIAL INPUT VOLTAGE	± 20V	TEMPERATURE RANGE, storage, PAD183-1	105C
OUTPUT CURRENT, peak, within SOA	1.5A	OPERATING TEMPERATURE, substrate	-40 to 85°C
POWER DISSIPATION, internal, DC	35W		

PARAMETER	TEST CONDITIONS ¹	MIN	TYP	MAX	PAD183-1 ⁹	UNITS
INPUT						
OFFSET VOLTAGE			1	5		mV
OFFSET VOLTAGE vs. temperature	Full temperature range		20	50		μV/°C
OFFSET VOLTAGE vs. supply				3		μV/V
BIAS CURRENT, initial ³				100		pA
BIAS CURRENT vs. supply				0.1		pA/V
OFFSET CURRENT, initial				50		pA
INPUT RESISTANCE, DC			100			G Ω
INPUT CAPACITANCE			4			pF
COMMON MODE VOLTAGE RANGE				+Vs-15		V
COMMON MODE VOLTAGE RANGE				-Vs+8		V
COMMON MODE REJECTION, DC		110	118			dB
NOISE	100kHz bandwidth, 1kΩ R _s		10			μV RMS
GAIN						
OPEN LOOP, DC	R _L = 10kΩ, C _c =22pF	108	120			dB
GAIN BANDWIDTH PRODUCT @ 1MHz	C _c =22pF		18			MHz
PHASE MARGIN	Full temperature range	60				degree
OUTPUT						
VOLTAGE SWING	I _o = 1.5A	+Vs-10	+Vs-6.5			V
VOLTAGE SWING	I _o = -1.5A	-Vs+10	-Vs+7			V
CURRENT, continuous, DC				1.5		A
SLEW RATE, A _v =-50	C _c = 22 pF		100			V/μS
SETTLING TIME, to 0.1%	2V Step, C _c = 22 pF		4			μS
RESISTANCE	No load, DC		16			Ω
POWER SUPPLY						
VOLTAGE		± 15	± 150	± 175		V
CURRENT, quiescent			21	26		mA
THERMAL						
RESISTANCE, AC, junction to air or case ⁶	Full temperature range, f ≥ 60Hz			2.4 to air	2.1 to case	°C/W
RESISTANCE, DC junction to air or case	Full temperature range			3.6 to air	3.1 to case	°C/W
TEMPERATURE RANGE, substrate		-40		85	85	°C
TEMPERATURE RANGE, ambient ⁵		-40		70	NA	°C
FAN, 40mm dc brushless, ball bearing						
OPERATING VOLTAGE			12		NA	V
OPERATING CURRENT			50		NA	mA
AIR FLOW			7.5		NA	CFM
RPM			7000		NA	RPM
NOISE			30		NA	dB
L10, life expectancy, 50°C ⁸			45		NA	kHrs
L10, life expectancy, 25°C ⁸			60		NA	kHrs

NOTES:

1. Unless otherwise noted: T_c = 25°C, compensation C_c = 150pF, DC input specifications are ± value given, power supply voltage is typical rating.

2. Derate internal power dissipation to achieve high MTBF.

3. Doubles for every 10°C of case temperature increase.

4. +Vs and -Vs denote the positive and negative supply voltages to the output stage. +Vcc and -Vcc denote the positive and negative supply voltages to the small signal stages. +Vcc and -Vcc may not be more than + and - 15V greater than +Vs and -Vs respectively.

5. Limited by fan characteristics. During operation, even though the heat sink may be at 85°C the fan will be at a lower temperature.

6. Rating applies if the output current alternates between both output transistors at a rate faster than 60Hz.

7. Power supply voltages +Vcc and -Vcc must not be less than +Vs and -Vs respectively. Total voltage +Vcc to -Vcc 350V maximum.

8. L10 refers to the time it takes for 10% of a population of fans to fail. Lower ambient temperature increases fan life.

9. Specifications for the PAD183-1 are the same as for the PAD183 except as shown in this column.

SAFETY FIRST

The operating voltages of the PAD183 are potentially deadly. When developing an application circuit it is wise to begin with power supply voltages as low as possible while checking for circuit functionality. Increase supply voltages slowly as confidence in the application circuit increases. Always use a “hands-off” method whereby test equipment probes are attached only when power is off.

COOLING FAN

The PAD183 relies on its fan for proper cooling of the amplifier. Make sure that air flow to the fan and away from the heat sink remains unobstructed. The cooling method used is impingement cooling, which means that cool air is pushed into the heat sink and warm air is exhausted through the spaces between the heat sink fins. To eliminate electrical noise created by the cooling fan we recommend a 47 μ F capacitor placed directly at the point where the fan wires connect to the PCB. See application note AN-24 for further details.

MOUNTING THE PAD183 AMPLIFIER

The amplifier is supplied with four 4-40 M/F hex spacers at the four corners of the amplifier. Once the amplifier is seated, secure the module with the provided 4-40 nuts and torque to 4.7 in lb [53 N cm] max. See “**Dimensional Information**” for a detailed drawing. It is recommended that the heat sink be grounded to the system ground. This can easily be done by providing a grounded circuit board pad around any of the holes for the mounting studs.

MOUNTING THE PAD183-1 AMPLIFIER

In most applications the amplifier must be attached to a heat sink. Spread a thin and even coat of heat sink grease across the back of the PAD183-1 and also the heat sink where the amplifier is to be mounted. Push the amplifier into the heat sink grease on the heat sink while slightly twisting the amplifier back and forth several times to bed the amplifier into the heat sink grease. On the final twist align the mounting holes of the amplifier with the mounting holes in the heat sink and finish the mounting using 4-40 hex male-female spacers and torque to 4.7 in lb [53 N cm] max. Mount the amplifier to the mother board with 4-40 X 1/4” screws. See Dimensional Information for additional recommendations.

PHASE COMPENSATION

The PAD183 **must** be phase compensated. The compensation capacitor, C_C , is connected between pins 2 and 3. The compensation capacitor must be an NPO type capacitor rated for the full supply voltage (350V). On page 2, under Amplifier Pinout and Connections, you will find a table that gives recommended compensation capacitance values for various circuit gains and the resulting slew rate for each capacitor value. Consult also the small signal response and phase

response plots for the selected compensation value in the Typical Performance Graphs section. A compensation capacitor less than 10pF is not recommended.

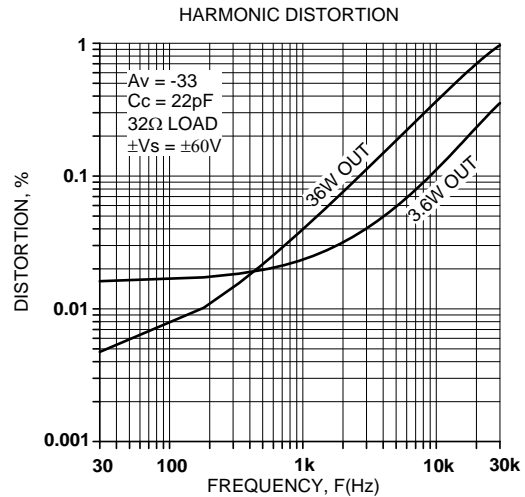
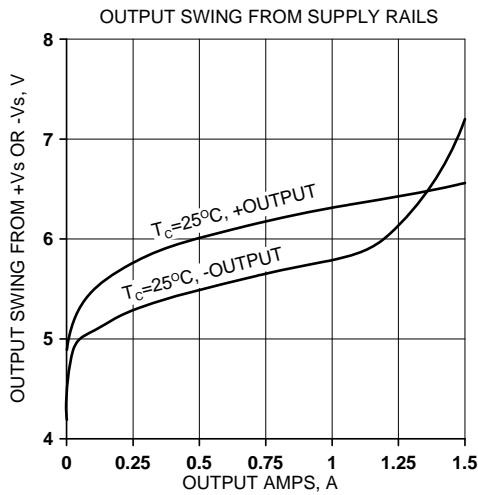
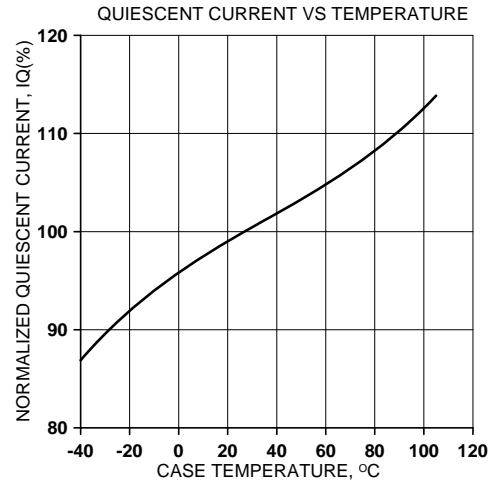
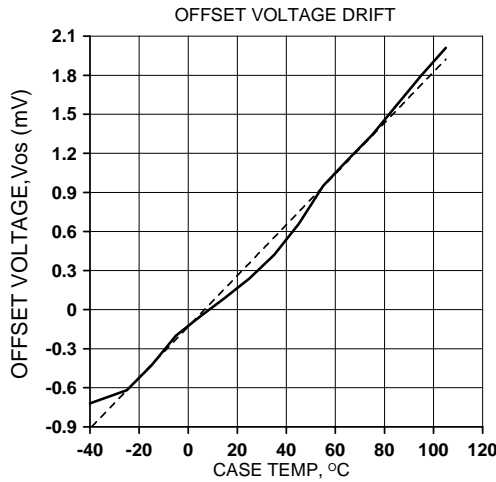
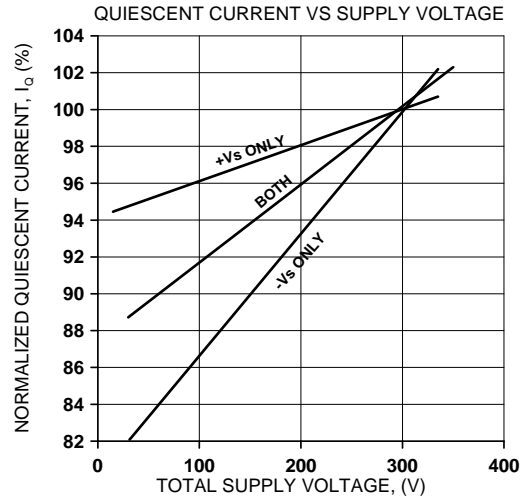
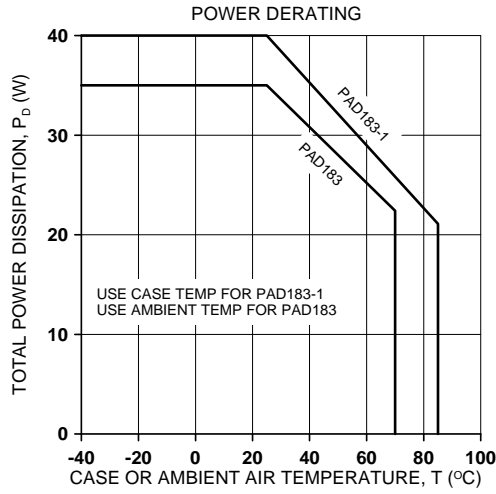

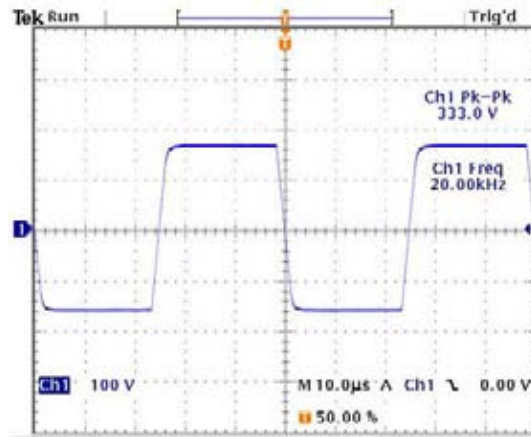
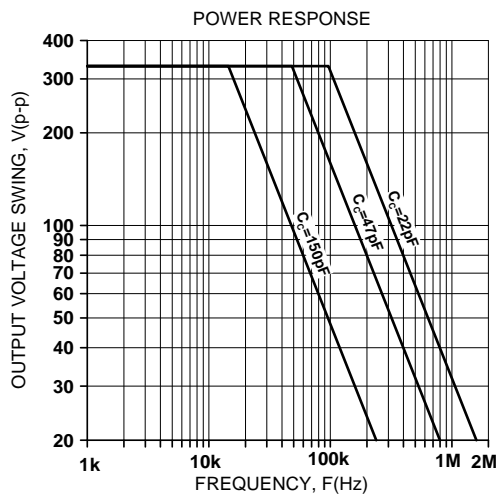
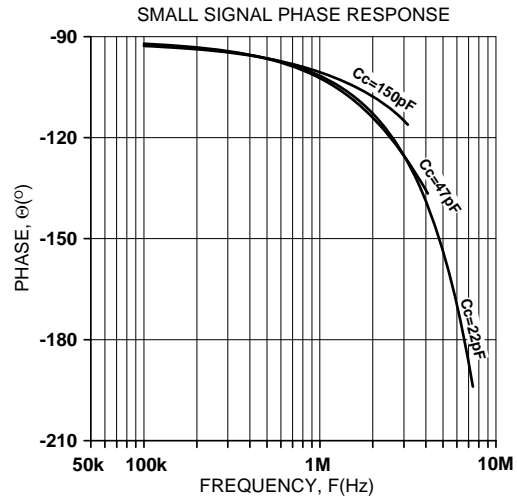
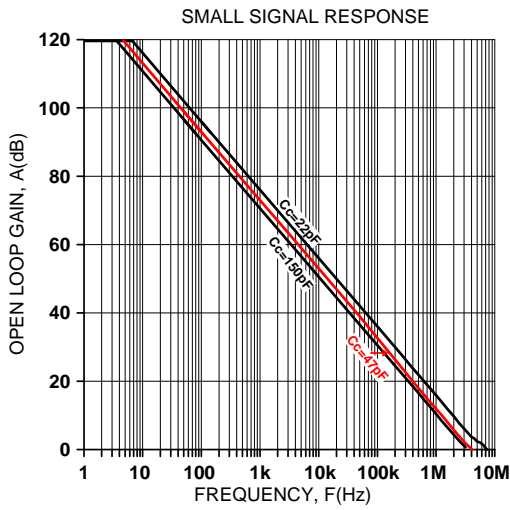

$G=-36, C_c=22\text{pF}$

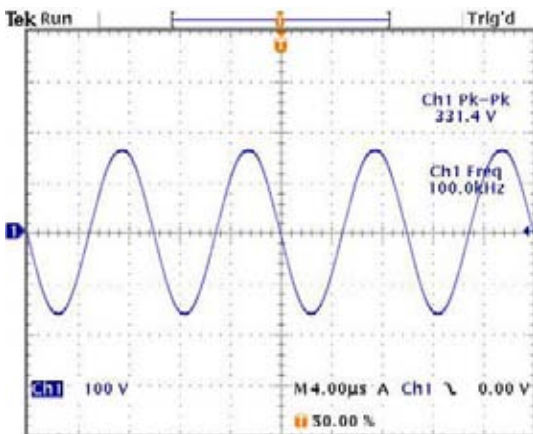

$G=-36, C_c=22\text{pF}$

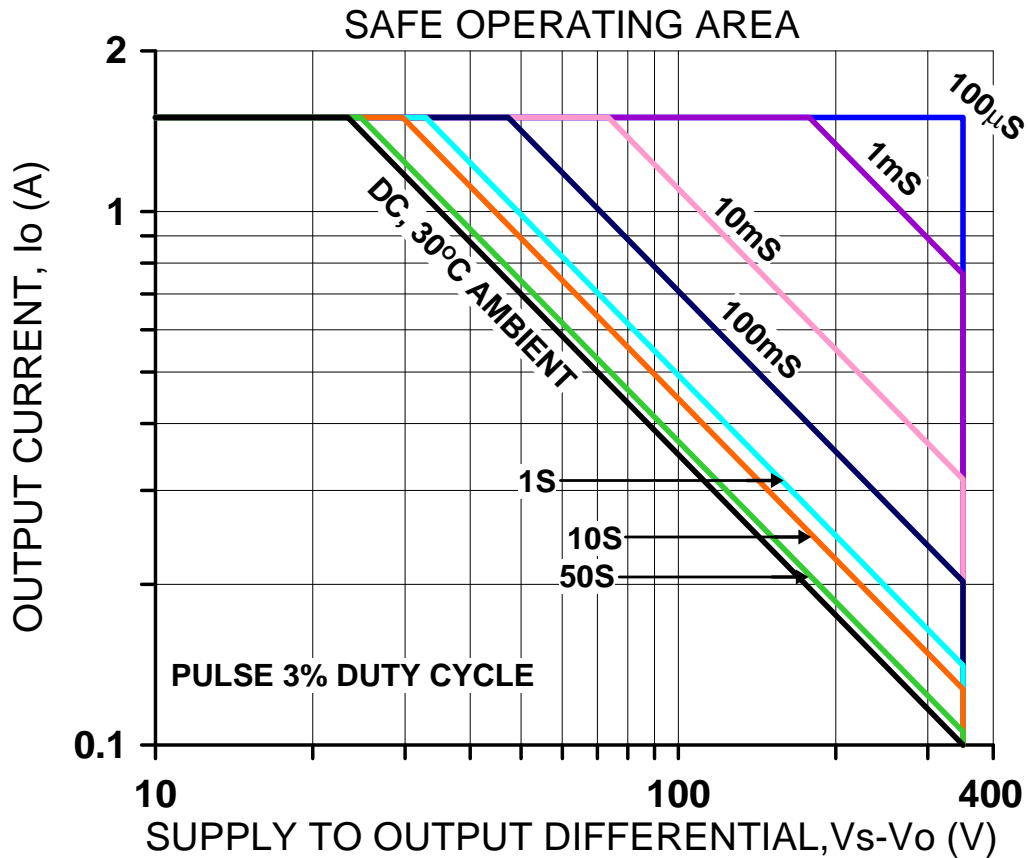

SAFE OPERATING AREA

The safe operating area (SOA) of a power amplifier is its single most important specification. The SOA graph presented above serves as a first approximation to help you decide if the PAD183 will meet the demands of your application. But a more accurate determination can be reached by making use of the **PAD Power**™ spreadsheet which can be downloaded from the website. While the graph above adequately shows DC SOA and some pulse information it does not take into account ambient temperatures higher than 30°C, AC sine, phase or non-symmetric conditions that often appear in real-world applications. The **PAD Power**™ spreadsheet takes all of these effects into account.

PowerAmp Design ♦ PAD183 ♦ COMPACT HIGH VOLTAGE OP AMP

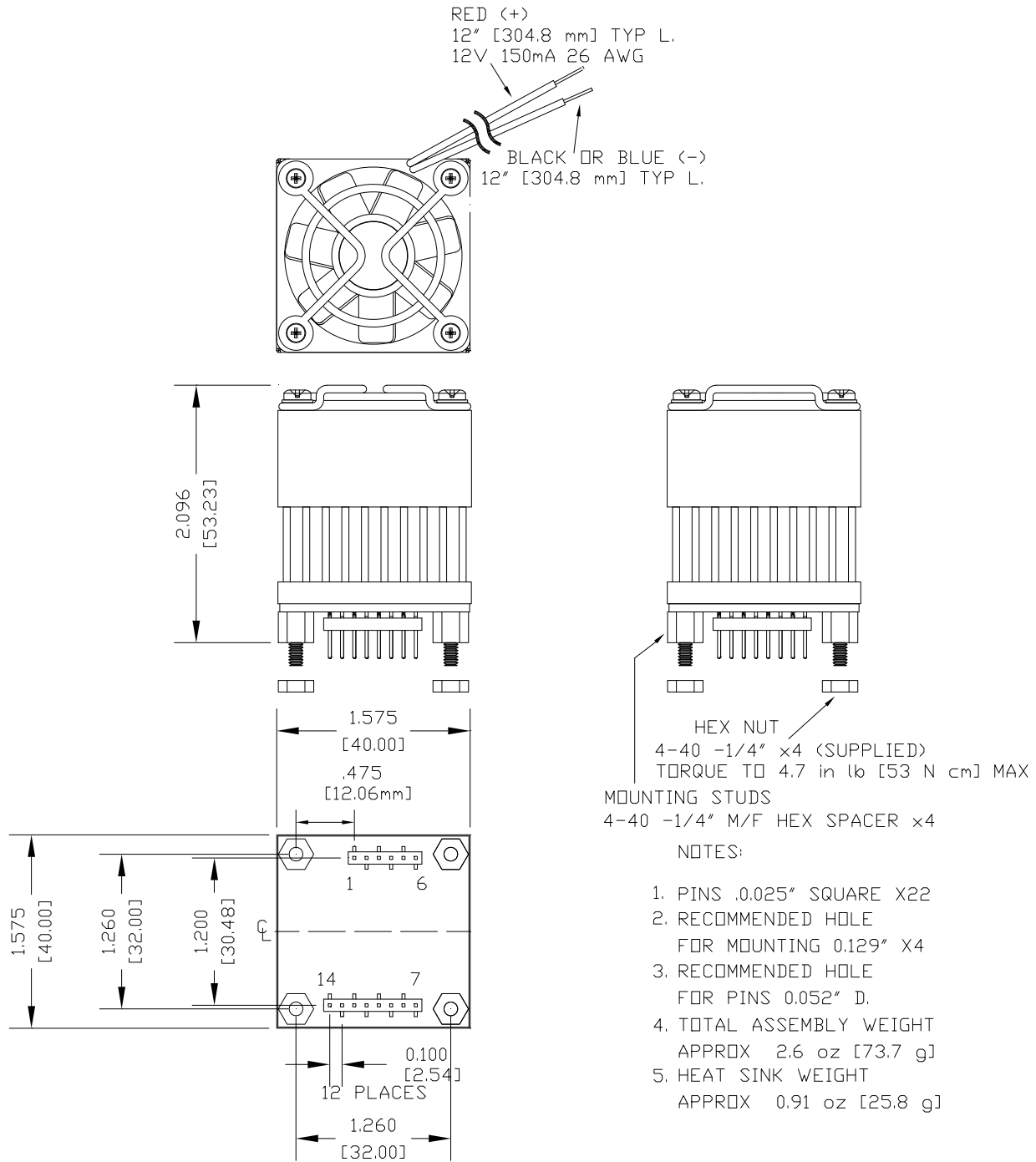

PowerAmp Design ♦ PAD183 ♦ COMPACT HIGH VOLTAGE OP AMP

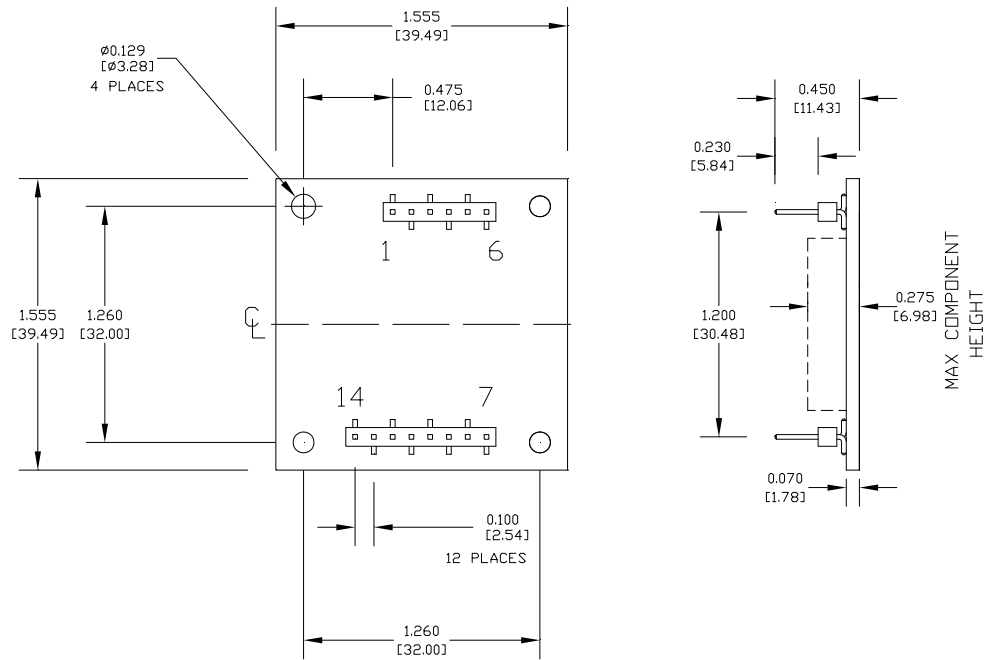

- NOTES: 1: DIMENSIONS ARE INCHES, [mm]
 2: PINS 0.025" SQUARE [0.635mm], GOLD PLATED
 3: RECOMMENDED HOLE FOR MOUNTING 0.129" D. x2 [3.277mm]
 4: RECOMMENDED HOLE FOR PINS 0.052" D. [1.321mm]
 5: HIGHLY RECOMMENDED THAT AMPLIFIER IS MOUNTED INTO CAGE JACKS USING PAD PART NUMBER CJS01. USE 0.062" [1.575mm] HOLE FOR CAGE JACKS.
 6: HIGHLY RECOMMENDED THAT AMPLIFIER IS MOUNTED INTO HEAT SINK WITH 4-40 M/F SPACERS TO PROVIDE STRAIN RELIEF FOR PINS. SEE DRAWING BELOW.

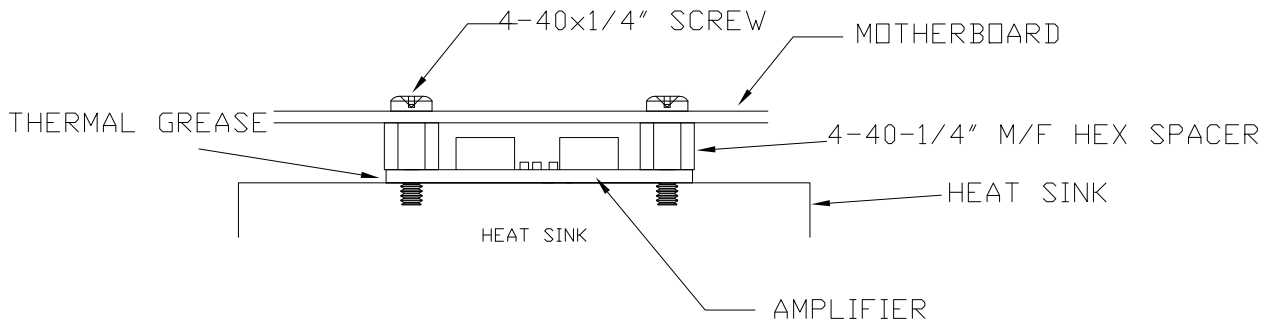

PAD183-1

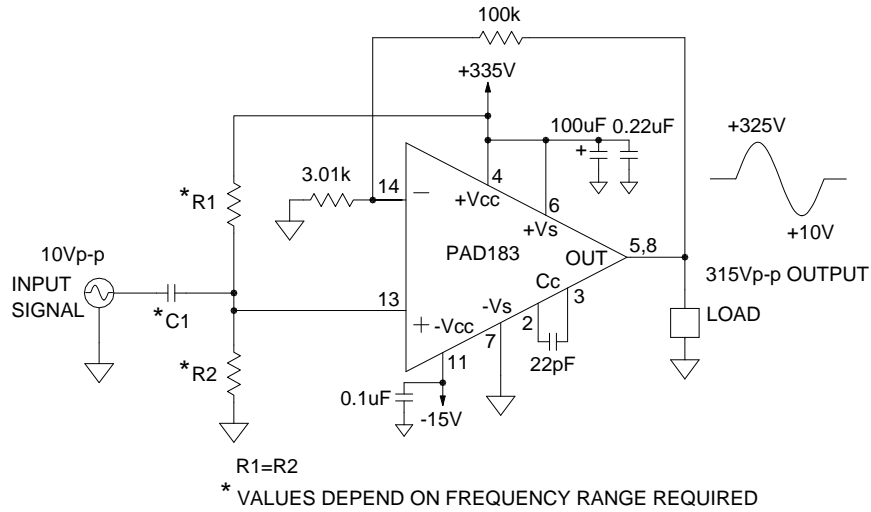

FIGURE 1.
SINGLE HIGH-CURRENT POWER SUPPLY CIRCUIT

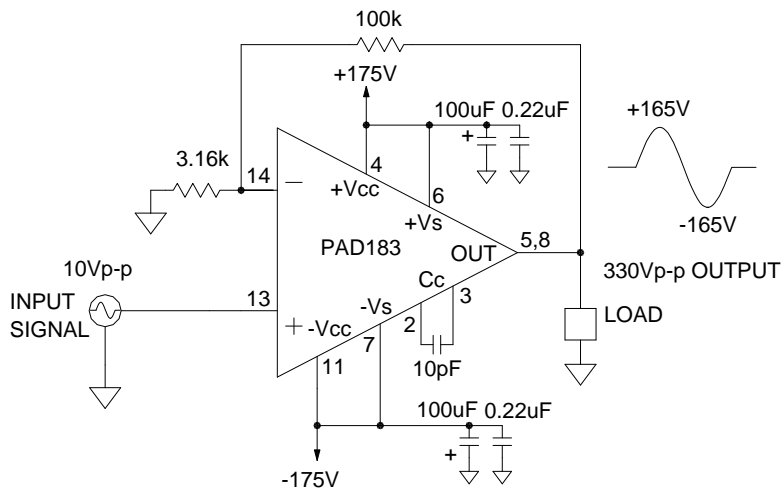

FIGURE 2.
DUAL HIGH-CURRENT POWER SUPPLY CIRCUIT

Power Amp Design ♦ PAD183 ♦ COMPACT HIGH VOLTAGE OP AMP