

Power Amp Design

EVALUATION KIT FOR PAD119

EVAL119

Rev 03-08-2007

INTRODUCTION

The EVAL119 assembled evaluation kit provides a convenient method to become familiar with the operation of the PAD119 operational amplifier before your application circuit is committed to production. Some assembly is required since some user selections are needed depending on the application. For example, a current limit resistor value needs to be selected by the user. Also, there are several PCB mounting options available.

Critical connections for power supply bypassing and compensation are pre-wired. Connections are also provided for implementing fold-over current limit as well as standard current limit with the optional PAD123 Current Limit Accessory Module. Fold-over current limit components are not provided since each application will have different requirements. Diode clamps on each power supply and the output connections are provided for those applications in which significant inductive kickback may be found. Terminal strips are also provided for input and output signals and power.

ASSEMBLY STEPS

Refer to the Illustrated Parts List for the components mentioned in each assembly step. Notice that the PCB for this kit is the EVAL118DIN, the same PCB used for the EVAL118 evaluation kit.

1. Notice that the printed circuit board (PCB) is labeled on one side as the "DUT SIDE" and the other side as "CIRCUIT" side.
2. As shown in the illustrated parts list, cage jack strips were used to provide you with the assembled version of this evaluation kit. The carrier strips left over from the assembly have been included with the kit and can be used as sockets for the components you will use to complete your application circuit. If desired you can cut and solder these sockets at the input locations for the PAD119 and PAD123 and other locations as desired. This can save soldering and unsoldering components as the needs of your application circuit change.
3. Refer to "Jumper Selection" below the Circuit Diagram for the EVAL119. Install the required jumpers at the locations indicated depending on the options you have chosen. Refer to the data sheet for the PAD123 for complete information on current limit options.
4. This step may require a soldering temperature higher than normal and/or a larger soldering iron tip. Three current limiting sense resistors, R_S , are provided; one 0.005 Ω , one 0.010 Ω and one 0.015 Ω . Refer to the data sheet for the PAD123 to determine which resistor value best fits your application (if you have chosen not to use the PAD123 module select the 0.005 Ω

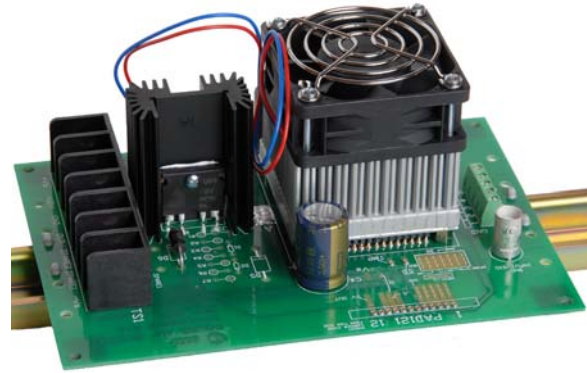

Assembled EVAL119 with PAD119 mounted.
Optional DIN rail mounting shown.

resistor or install a length of heavy buss wire into the outer two holes at the location for the sense resistor R_S). Smear a small amount of heat sink grease on the back of the selected resistor and then attach the resistor loosely to heat sink HS1 at R_S with a 4-40 X 1/2" screw and nut. The plastic nut driver supplied with this kit will help here. Do not tighten the screw at this time. Tighten the 4-40 resistor mounting hardware. Solder the resistor from the "CIRCUIT SIDE" of the PCB making sure that the holes are completely filled with solder.

5. D3 and D5 are not supplied since the type varies with the application.











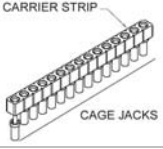

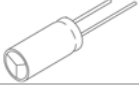
6. The evaluation kit PCB can be mounted in several ways.
Option 1- Chassis mount. Use #6 x 1/4" M/F hex standoffs, #6 X 1/4" screw and #6 nut (not supplied) attached to the PCB at the four corners of the PCB and the chassis. Use one of the rubber bumpers supplied at the indicated place at the center of the amplifier on the "CIRCUIT SIDE" of the PCB.

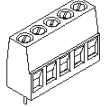
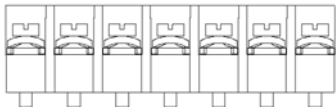
Option 2- Bench-top mount. Use the five rubber bumpers supplied. These are "stick-on" components. Remove the release paper from each bumper and apply the bumper to the square outlines on the "CIRCUIT SIDE" of the PCB.

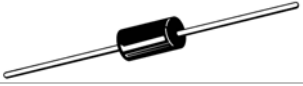
Option 3- DIN rail mount. The PCB can be mounted to either 1 or 2 DIN rails. For mounting the PCB to one DIN rail press the adaptors into the PCB in the holes at the edges of the PCB at locations 1 and 2 from the "CIRCUIT SIDE" of the PCB. Make sure that the plastic tines have fully spread out on the "DUT SIDE" of the PCB. If mounting to 2 DIN rails is desired, mount DIN rail adaptors at locations 3, 4, 5 and 6 in a similar manner. The center to center dimension of the DIN rails is to be 2.00"

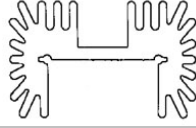
7. Components for locations R1-R7, D1, D2 are for the optional fold-over current limiting and are not supplied. Refer to the data sheet of the PAD119 to find out how to apply circuits that require these components.
8. Remove the 4 hex nuts from the mounting spacers of the PAD119.
9. Align the 4 studs of the mounting spacers with the mounting holes in the PCB. Be sure that the amplifier's pin 1 aligns with pin 1 on the PCB. Slowly lower the amplifier into the PCB, making sure that the pins of the amplifier and the cage jacks mate. Push the amplifier into the PCB until the mounting spacers meet the PCB.
10. Fasten the amplifier to the PCB with the 4 hex nuts previously removed. Do not over-tighten the nuts as this may strip the mounting studs. The provided plastic nut starter can assist you here.
11. Strip 1/8" of insulation from the wires connected to the fan. Twist and tin the wire ends. Insert the red wire into the cage jack labeled "+" at the location marked "FAN" on the PCB. Likewise insert the blue or black wire into the cage jack labeled "-" at the location marked "FAN".
12. Add components as necessary to evaluate your application circuit. You can utilize the evaluation kit schematic and PCB views to map out your circuit and components. **Remember, if you are using the PAD123 Current Limit Accessory Module additional components will be needed to program the operation of the module. See the PAD123 data sheet.**
13. Remember that the PAD119 **must** be compensated to operate correctly. See the PAD119 data sheet on Page 4 under PHASE COMPENSATION. Your selected phase compensation capacitor will be installed at "C_C" on the evaluation kit PCB.
14. If you have chosen to use the PAD123 accessory module install it at this time making sure that pin 1 on the module is aligned with the pin 1 marking on the PCB.
15. The evaluation kit assembly is complete.

Note that the PAD119 and PAD123 are purchased separately.

✓	Ref	Qty	Description	Mfg/Distributor	Mfg. Part Number	Illustration (not to scale)
<input type="checkbox"/>	Amplifier Pins 1-30 + TPs	3	Cage Jacks w/carrier strip 32 wide	Power Amp Design	NA	
<input type="checkbox"/>	C1, 2, 5, 6	4	Chip Capacitor, 1uF	Novacap	1825B105K201N	
<input type="checkbox"/>	C3, 4	2	Electrolytic Capacitor, 220uF	Panasonic/Digi-Key	EEU-EB2D221S	
<input type="checkbox"/>	JP1	1	BNC Jack	AMP/Digi-Key	5221123-2	
<input type="checkbox"/>	JP2	1	Terminal Block	Phoenix/Digi-Key	1729157	
<input type="checkbox"/>	TS1	1	Terminal Strip	Molex/Newark	38660-7807	
<input type="checkbox"/>	R _s	3	Sense Resistor	Isotek Isotek Isotek	PBV-R005-1.0 (5mΩ) PBV-R010-1.0 (10mΩ) PBV-R015-1.0 (15 mΩ)	
<input type="checkbox"/>	D4, 6	2	Diode, Fast Recovery	ON Semi/Digi-Key	MUR460RL	
<input type="checkbox"/>	NA	5	Rubber Bumper	3M/Digi-Key	SJ5518	
<input type="checkbox"/>	HS1	1	Heat Sink	Wakefield/Mouser	67720ABP	
<input type="checkbox"/>	NA	1	Nut Starter	Menda/Jensen Tool	200	
<input type="checkbox"/>	NA	1	Heat Sink Grease	NTE/Jameco	NTE303	
<input type="checkbox"/>	NA	1	4-40X1/2" screw & 4-40 nut	NA	NA	
<input type="checkbox"/>	NA	4	35mm DIN Rail Adaptor	Scidyne	121-0014	
<input type="checkbox"/>	NA	1	PCB	Power Amp Design	EVAL119DIN	NA

CIRCUIT DIAGRAM

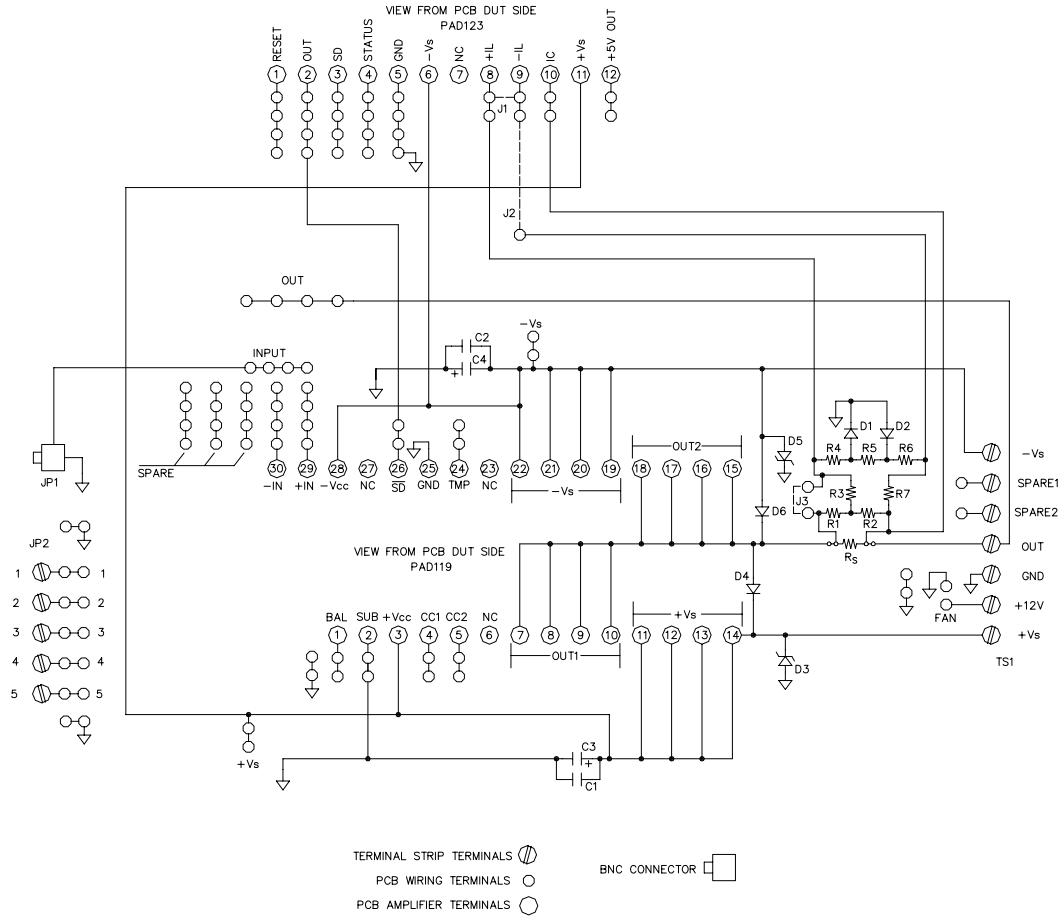

JUMPER SELECTION

To use the PAD119 and PAD121 together **without** fold-over current limit insert jumpers J1, 3.

To use the PAD119 and PAD121 together **with** fold-over current limit insert jumpers J2.

Assembled EVAL119 with optional DIN rail PCB mounting and PAD119 installed

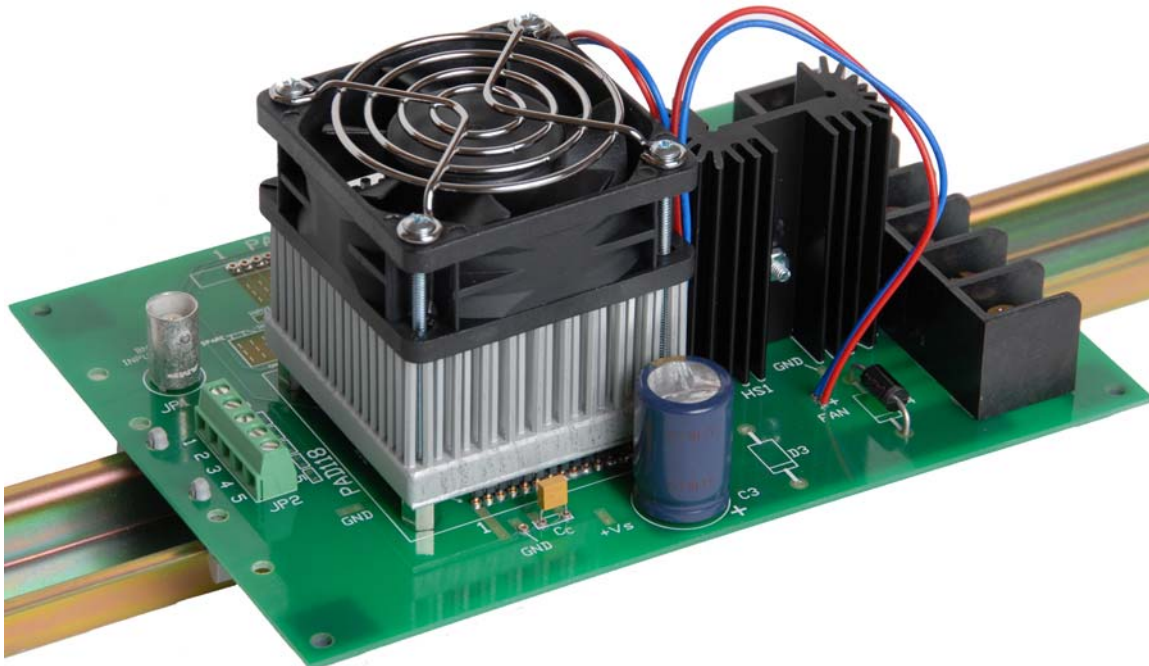
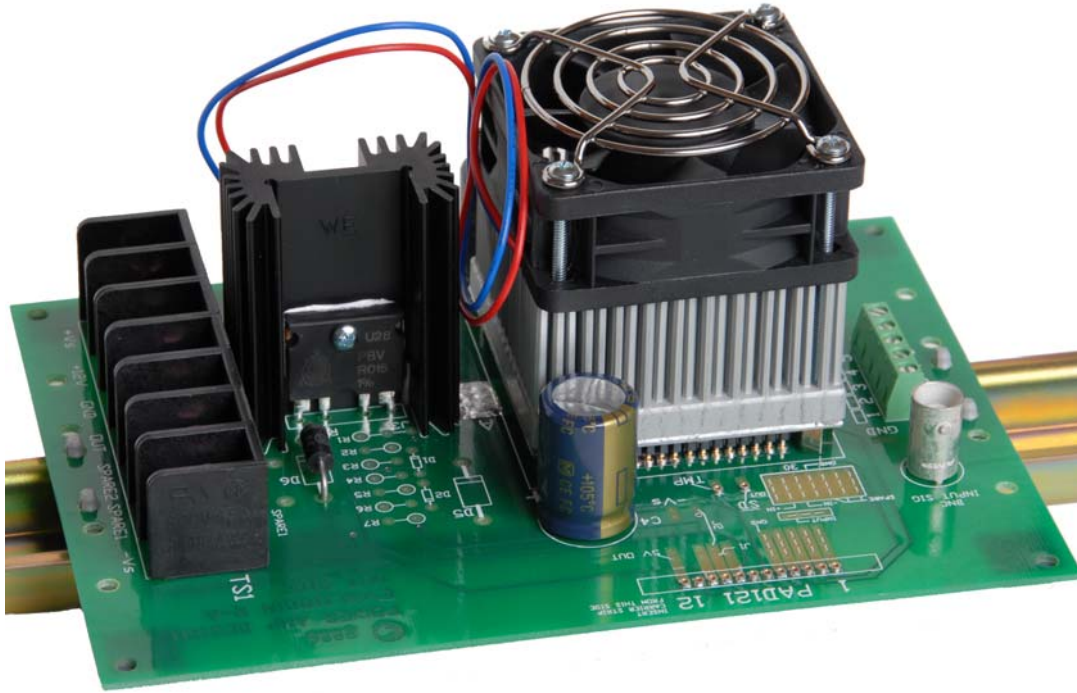

BOARD OUTLINE DIMENSIONS

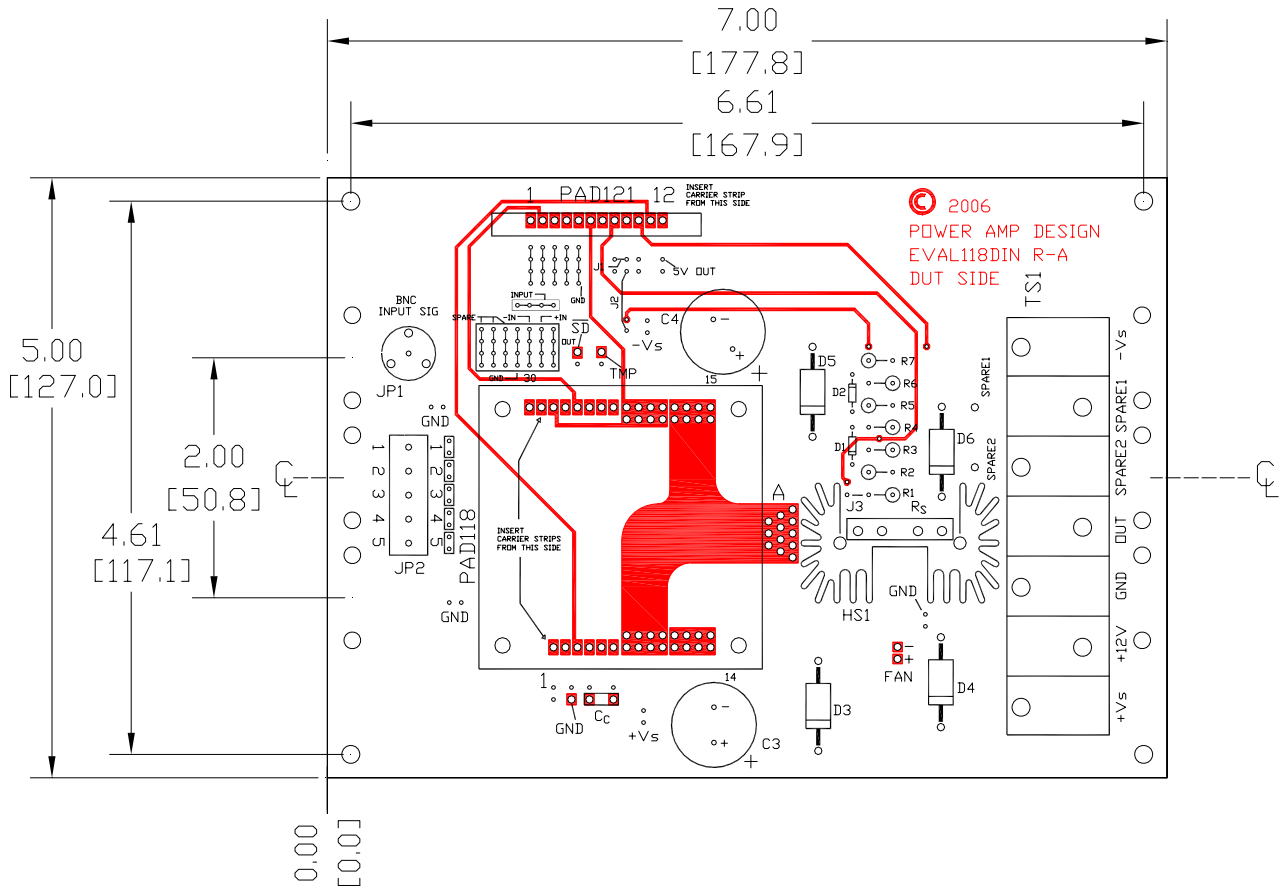

Power Amp Design ♦ EVAL119 ♦ EVALUATION KIT FOR PAD119