

# PowerAmp Design

EVALUATION KIT FOR MODELS PAD112/ PAD113

EVAL112

Rev H

## INTRODUCTION

The EVAL112 evaluation kit provides a convenient method to become familiar with the operation of amplifier models PAD112 and PAD113 before your application circuit is committed to production. Some assembly is required since user selections are needed depending on the application. For example, a current limit resistor value needs to be selected by the user. Also, there are several PCB mounting options available.

Critical connections for power supply bypassing and compensation are pre-wired. Fold-over current limit components are not provided since each application will have different requirements. Connections are also provided for diode clamps on each power supply and the output for those applications in which significant inductive kickback may be found. Terminal strips are also provided for input and output signals and power. Sockets are also provided for the optional PAD123 or PAD125 Current Limit Accessory Modules as well as the PAD131 Fan Controller Accessory Module.

## ASSEMBLY STEPS

*Please note that the #1 cause of problems for evaluation kit users is not reading and following the directions (all of them). The #2 cause of problems is poor solder joints (cold or bridging). Don't become a statistic. ✓ each step.*

Refer to the Illustrated Parts List for the components mentioned in the assembly steps. Note that some heavy PCB copper planes and some heavy component leads are soldered in this kit. This may require a larger soldering iron tip and/or higher soldering iron temperatures than might normally be used. These steps are marked with an asterisk (\*).

□ 1. Notice that the printed circuit board (PCB) is labeled on one side as the "DUT SIDE" and the other side as "CIRCUIT" side.

□ 2. As shown in the illustrated parts list, cage jack strips were used to provide you with the assembled version of this evaluation kit. The carrier strips left over from the assembly have been included with the kit and can be cut to length and used as sockets for the components you will use to complete your application circuit. You can solder these sockets at the input locations for the amplifier and other locations as desired. This can save soldering and unsoldering components as the needs of your application circuit change.

□ 3. Refer to "Jumper Selection" below the Circuit Diagram for the EVAL112 on page 4. Install the required jumpers at the locations indicated depending on the option you have chosen. Jumpers of various lengths are included in this kit. Refer to the



**Assembled EVAL112 with amplifier installed. Optional accessory modules also installed. Optional 35mm DIN rail mounting shown.**

datasheet for the amplifier for complete information on current limit options. Jumpers for option 1 are already installed. Remove and replace the jumpers as needed for the option you have chosen.

□ 4.\* Four current limiting sense resistors,  $R_S$ , are provided; two 0.47  $\Omega$ , one 1.0  $\Omega$  and one 2.0  $\Omega$ . Likewise, there are four locations on the PCB for these resistors. The PCB ties all four of the locations in parallel. The resistors can be used individually at any location or several can be used to fine tune the final value desired. See the datasheet for the amplifier to determine the best value for your application. Solder the resistor(s) from the "CIRCUIT SIDE" of the PCB.

□ 5. D3 and D5 are transient voltage suppressor diodes and are not supplied since the type (breakdown voltage) varies with the application. They are not necessary for every application. They are most commonly used in application circuits where kickback from the load may force the supply voltage above the limits of the amplifier.











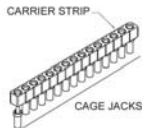

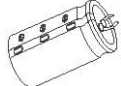

□ 6. The evaluation kit PCB can be mounted in several ways. **Option 1- Chassis mount.** Use #6 standoffs and screws (not supplied) attached to the PCB at the four corners of the PCB.

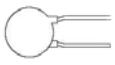
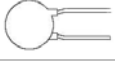
**Option 2- Bench-top mount.** Use the five rubber bumpers supplied. These are "stick-on" components. Remove the release paper from each bumper and apply the bumper to the square outlines on the "CIRCUIT SIDE" of the PCB.

**Option 3- DIN rail mount.** The PCB can be mounted to a 35mm DIN rail. For mounting the PCB to a DIN rail press the adaptors into the PCB in the holes at the edges of the PCB at locations 1 and 2 from the "CIRCUIT SIDE" of the PCB. Make sure that the plastic tines have fully spread out on the "DUT SIDE" of the PCB.

- 7. Components for locations R1-R7, D1, D2 are for the optional fold-over current limiting and are not supplied. Refer to the datasheet of the amplifier model to find out how to apply circuits that require these components.
- 8. Remove the 4 hex nuts from the mounting spacers of the amplifier.
- 9. Align the 4 studs of the mounting spacers with the mounting holes in the PCB. Be sure that the amplifier's pin 1 aligns with pin 1 on the PCB. Slowly lower the amplifier into the PCB, making sure that the pins of the amplifier and the cage jacks mate. Push the amplifier into the PCB until the mounting spacers meet the PCB.
- 10. Fasten the amplifier to the PCB with the 4 hex nuts previously removed. Do not over-tighten the nuts as this may strip the mounting studs. The provided plastic nut starter can assist you here.
- 11. If necessary, strip 1/8" of insulation from the wires connected to the fan. Twist and tin the wire ends. Insert the red wire into the cage jack labeled "+" at the location marked "FAN" on the PCB. Likewise insert the blue or black wire into the cage jack labeled "-" at the location marked "FAN". Do not solder the wires into the sockets.
- 12. Use the bread-boarding area to add the external components necessary to program the amplifier gain and other circuit requirements to evaluate your application circuit. You can use the evaluation kit schematic and PCB views to map out your circuit.
- 13. Remember that the amplifier must be compensated to operate correctly. See the amplifier datasheet on Page 4, under PHASE COMPENSATION. The selected phase compensation capacitor will be installed at "C<sub>C</sub>" on the evaluation kit PCB. A 470pF capacitor has already been installed in your kit. Another value may better suit your application. Remove and replace the capacitor as necessary for your application. 10pF, 33pF and 100pF capacitors are also included with the kit. C<sub>C</sub> must be rated for at least 500V. A temperature stable type capacitor is required—an X7R ceramic, for example, or an NPO type.
- 14. The evaluation kit assembly is complete. Be sure you have read and followed all the assembly steps. Do not forget any jumpers that need to be installed. Inspect the circuit board for solder shorts or poor solder joints. An illuminated magnifier is helpful.
- 15. **Before applying power to your circuit set the power supply for ±20V and set the power supply current limit to approximately 100mA. Use little or no load at first. Apply an input signal and check the output with an oscilloscope to verify proper functionality. This step can prevent damaging the amplifier or the circuit board should there be some mistake in assembly.**

*Note that the amplifier and accessory modules are purchased separately.*

✓	Ref	Qty	Description	Mfg/Distributor	Mfg. Part Number	Illustration (not to scale)
<input type="checkbox"/>	Amplifier Pins 1-22 + TPs	1	Cage Jacks w/carrier strip 32 wide	Power Amp Design	NA	
<input type="checkbox"/>	C1, 2	2	Chip Capacitor, .2μF, 500V	Novacap	1825B204M501NT	
<input type="checkbox"/>	C3, 4	2	Electrolytic Capacitor, 47μF, 500V	Panasonic/Digi-Key	ECOS2HP470BA	
<input type="checkbox"/>	JP1	1	BNC Jack	AMP/Digi-Key	5221123-2	
<input type="checkbox"/>	C5,6	2	Electrolytic Capacitor, 47μF 35V	Panasonic/Digi-Key	EEU-FC1V470	
<input type="checkbox"/>	JP2,3	2	Terminal Block	Phoenix/Digi-Key	1729157	
<input type="checkbox"/>	Cc	1	Capacitor, 470pF 1kV	Vishay/Mouser	562R10TST47	
<input type="checkbox"/>	Cc	1	Capacitor, 100pF 1kV	Vishay/Mouser	562R10TST10	
<input type="checkbox"/>	Cc	1	Capacitor, 33pF 1kV	Vishay/Mouser	561R10TCCQ33	
<input type="checkbox"/>	Cc	1	Capacitor, 10pF 1kV	Vishay/Mouser	561R10TCCQ10	
<input type="checkbox"/>	R <sub>s</sub>	4	Sense Resistor	Xicon/Mouser Xicon/Mouser Xicon/Mouser	(2) 262-0.47-RC (0.47Ω) 262-1.0-RC (1.0Ω) 262-2.0-RC (2.0Ω)	
<input type="checkbox"/>	D4, 6	2	Diode, Fast Recovery	ON Semi/Digi-Key	MUR460RL	
<input type="checkbox"/>	NA	5	Rubber Bumper	3M/Digi-Key	SJ5518	
<input type="checkbox"/>	NA	15 (5ea)	Jumper	3M/Mouser	923345-01-C (0.1 in) 923345-02-C (0.2 in) 923345-03-C (0.3 in)	
<input type="checkbox"/>	NA	1	Nut Starter	Menda/Jensen Tool	200	
<input type="checkbox"/>	NA	2	35mm DIN Rail Adaptor	Scidyne	121-0014	
<input type="checkbox"/>	NA	1	PCB	Power Amp Design	EVAL112 R-C	NA

CIRCUIT DIAGRAM

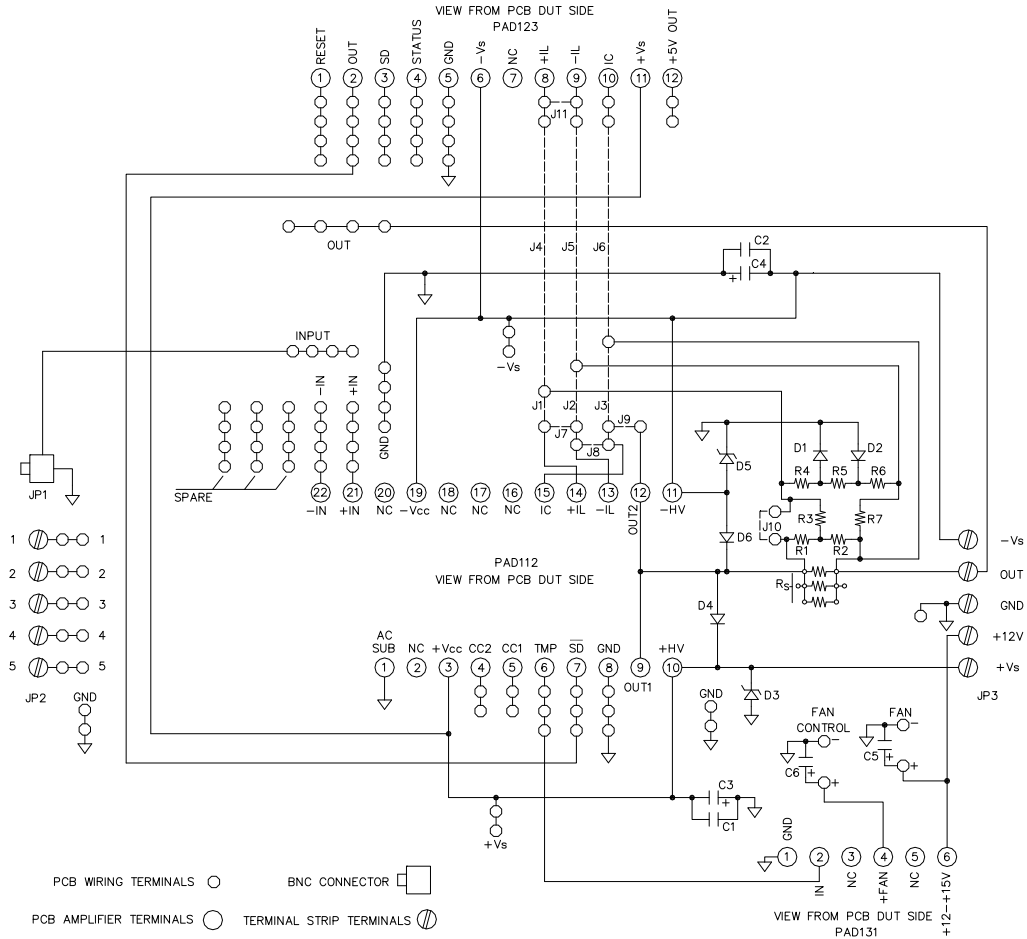

JUMPER SELECTION

Option 1: To use the amplifier alone **without** fold-over current limit insert jumpers J1, 3, 7, 10 only (**jumpers pre-installed for this option**).

Option 2: To use the amplifier alone **with** fold-over current limit use jumpers J1, 2, 3 only.

Option 3: To use the amplifier and current limit module together **without** fold-over current limit insert jumpers J4, 6,7, 8, 9, 10, 11 only.

Option 4: To use the amplifier and current limit module together **with** fold-over current limit insert jumpers J4, 5, 6, 7, 8, 9 only.

Refer to the **PAD Power™** Excel spreadsheet (available for download from the website) for assistance in calculating resistor values for fold-over current limiting.

TOP VIEW

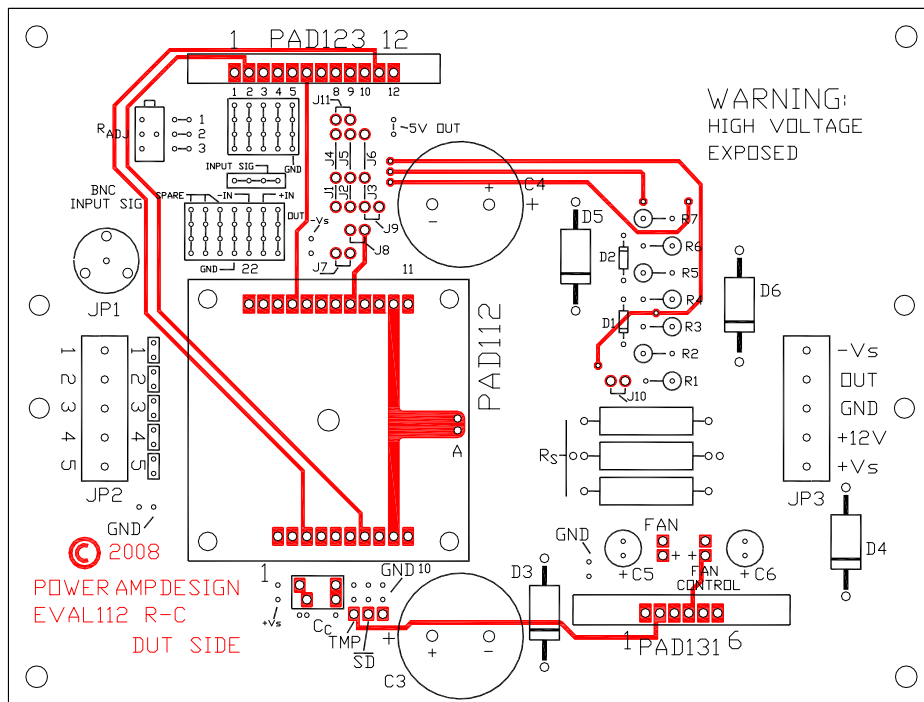

BOTTOM VIEW

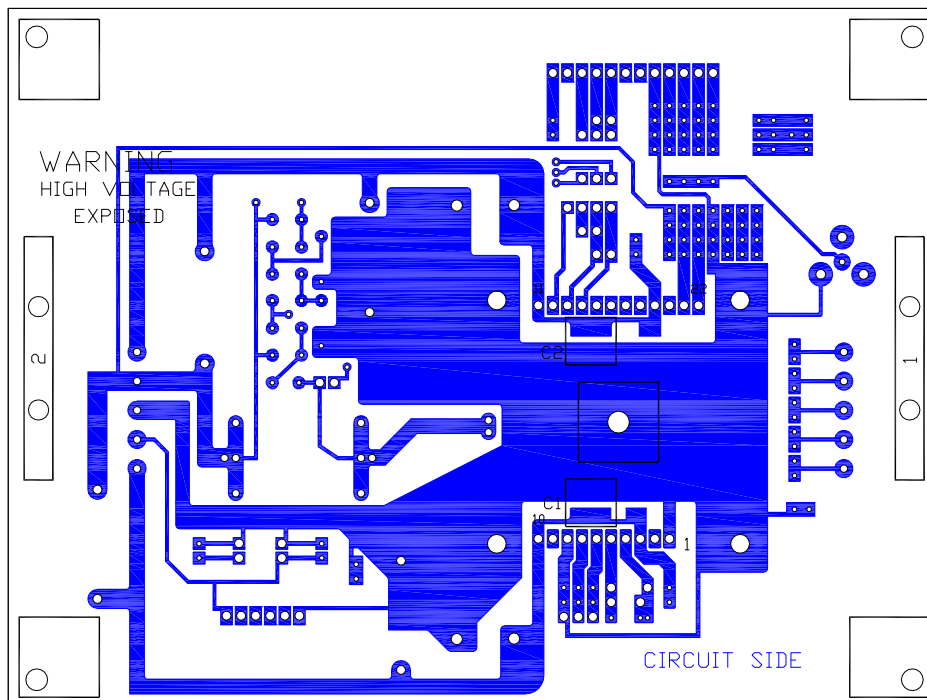

Power Amp Design ♦ EVAL112 ♦ EVALUATION KIT FOR MODELS PAD112/ 113

ASSEMBLED EVAL112 WITH AMPLIFIER AND ACCESSORY MODULES MOUNTED AND 35mm  
DIN RAIL

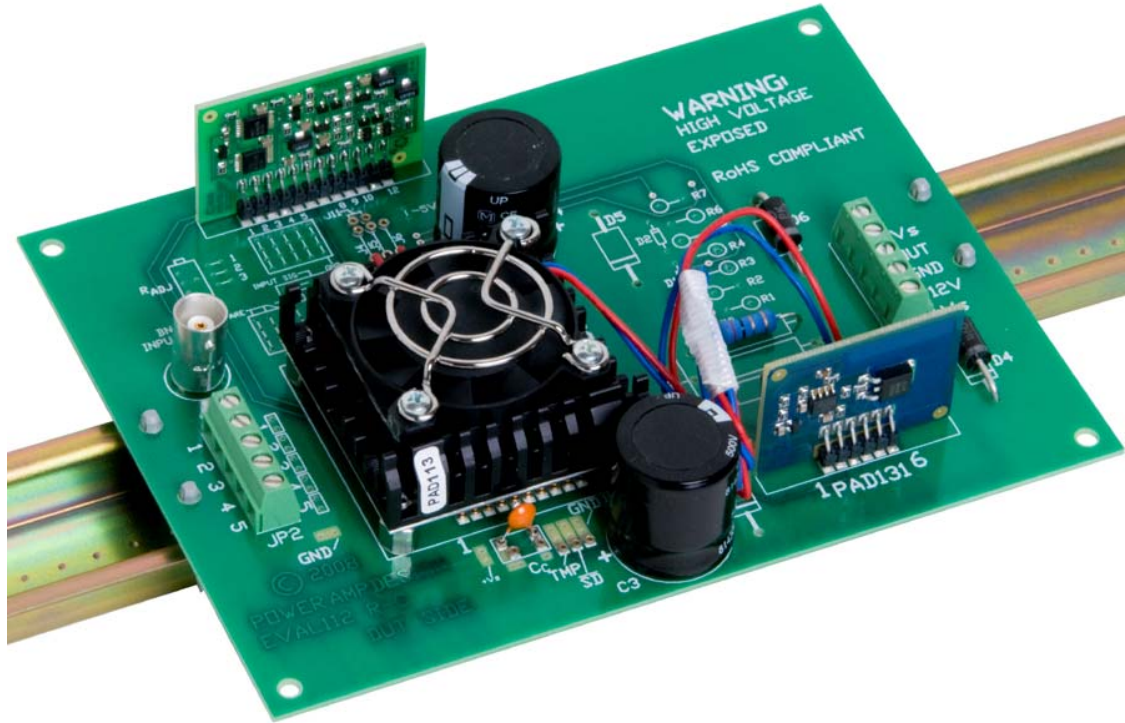

*PowerAmp Design* ♦ EVAL112 ♦ EVALUATION KIT FOR MODELS PAD112/ 113

**BOARD OUTLINE DIMENSIONS**

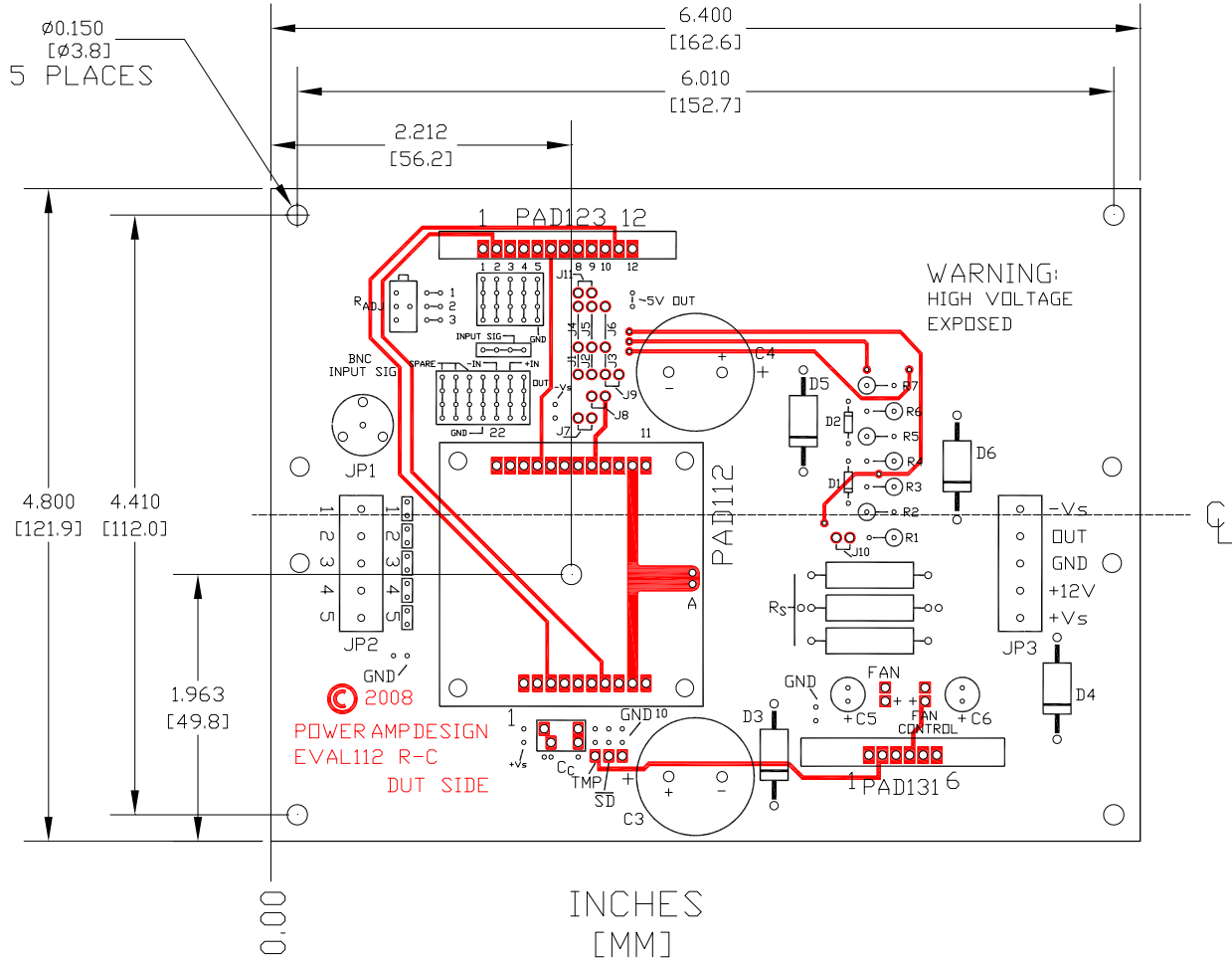

PowerAmp Design ♦ EVAL112 ♦ EVALUATION KIT FOR MODELS PAD112/ 113