

PowerAmp Design

EVALUATION KIT FOR MODELS PAD01/02/08

EVAL01

Rev A

INTRODUCTION

The EVAL01 evaluation kit provides a convenient method to become familiar with the operation of amplifier models PAD01, PAD02 or PAD08 before your application circuit is committed to production. Some assembly is required since user selections are needed depending on the application. For example, a current limit resistor will be selected. There are also several PCB mounting options available.

Critical connections for power supply bypassing and compensation are pre-wired. Connections are also provided for diode clamps on each power supply and the output for those applications in which significant inductive kickback may be found. Terminal strips are also provided for input and output signals and power.

ASSEMBLY STEPS

Please note that the #1 cause of problems for evaluation kit users is not reading and following the directions (all of them). The #2 cause of problems is poor solder joints (cold or bridging). Don't become a statistic. ✓ each step.

- 1. Notice that the printed circuit board (PCB) is labeled on one side as the "DUT SIDE" and the other side as "CIRCUIT" side.
- 2. D3 and D5 are transient voltage suppressor diodes and are not supplied since the type (breakdown voltage) varies with the application. They are not necessary for every application. They are most commonly used in application circuits where kickback from the load may force the supply voltage above the limits of the amplifier.
- 3. The evaluation kit PCB can be mounted in several ways.
Option 1- Chassis mount. Use #6 standoffs and screws (not supplied) attached to the PCB at the four corners of the PCB.
Option 2- Bench-top mount. Use the rubber bumpers supplied. These are "stick-on" components. Remove the release paper from each bumper and apply the bumper to the square outlines on the "CIRCUIT SIDE" of the PCB.
Option 3- DIN rail mount. The PCB can be mounted to a 35mm DIN rail. For mounting the PCB to a DIN rail press the adaptors into the PCB in the holes at the edges of the PCB at locations 1 and 2 from the "CIRCUIT SIDE" of the PCB. Make sure that the plastic tines have fully spread out on the "DUT SIDE" of the PCB.
- 4. Several current limiting resistors are provided: two 0.2Ω, two 0.3Ω, two 0.47Ω and two 2 Ω. Follow the amplifier model's datasheet to determine which resistor value to use for your application. The current limit circuit is not a precision

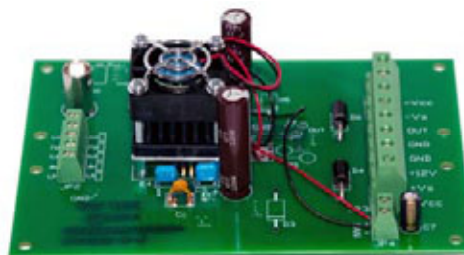

Assembled EVAL01 with amplifier installed.

circuit, but the approximate current limit value can be determined by:

$$I_L = \frac{0.7}{R_s}$$











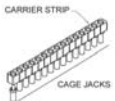





Where I_L is the desired current limit value and R_s is the current limit sense resistor value

There are locations in the PCB for mounting two of the various resistors in parallel so that the exact final value can be adjusted.

- 5. Remove the 4 hex nuts from the mounting spacers of the amplifier.
- 6. Align the 4 studs of the mounting spacers with the mounting holes in the PCB. Be sure that the amplifier's pin 1 aligns with pin 1 on the PCB. Slowly lower the amplifier into the PCB, making sure that the pins of the amplifier and the cage jacks mate. Push the amplifier into the PCB until the mounting spacers meet the PCB.
- 7. Fasten the amplifier to the PCB with the 4 hex nuts previously removed. Do not over-tighten the nuts as this may strip the mounting studs. The provided plastic nut starter can assist you here.
- 8. If necessary, strip 1/8" of insulation from the wires connected to the fan. Twist and tin the wire ends. Insert the red wire into JP4 (FAN) at "+" and the black or blue wire into JP4 at "-".
- 9. Use the bread-boarding area to add the external components necessary to program the amplifier gain and other circuit requirements to evaluate your application circuit. You can use the evaluation kit schematic and PCB views to map out your circuit.

- **10.** Remember that the amplifier must be compensated to operate correctly. See the amplifier datasheet on Page 4, under PHASE COMPENSATION. The selected phase compensation capacitor will be installed at “C_C” on the evaluation kit PCB. A 470pF capacitor has already been installed in your kit. Another value may better suit your application. Remove and replace the capacitor as necessary for your application. 33pF and 100pF capacitors are also included with the kit. C_C must be rated for the full supply voltage +Vs to -Vs is required. A temperature stable type capacitor is required—an X7R ceramic, for example, or an NPO type.
- **11.** The evaluation kit assembly is complete. Be sure you have read and followed all the assembly steps. Inspect the circuit board for solder shorts or poor solder joints. An illuminated magnifier is helpful. It is best to remove the solder flux solder joints where components were added.
- **12.** Before applying power to your circuit set the power supply for ±20V and set the power supply current limit to approximately 100mA. Use little or no load at first. Apply an input signal and check the output with an oscilloscope to verify proper functionality. This step can prevent damaging the amplifier or the circuit board should there be some mistake in assembly.

Note that the amplifier is purchased separately.

✓	Ref	Qty	Description	Mfg/Distributor	Mfg. Part Number	Illustration (not to scale)
<input type="checkbox"/>	Amplifier Pins 1-10 + Cc	1	Cage Jacks w/carrier strip 32 wide	Power Amp Design	CJS01	
<input type="checkbox"/>	C1, 2, 4, 5	4	Ceramic capacitor 0.47 µF, 450V	Murata/Mouser	RDED72W474K5E1C13A	
<input type="checkbox"/>	C3, 6	2	Electrolytic Capacitor, 47µF, 350V	United Chem- Con/Digi-Key	EKXJ351ELL470MJ40S	
<input type="checkbox"/>	JP1	1	BNC Jack	AMP/Digi-Key	5221123-2	
<input type="checkbox"/>	C7	2	Electrolytic Capacitor, 47µF 35V	Panasonic/Digi-Key	EEU-FC1V470	
<input type="checkbox"/>	JP2	1	Terminal Block 5 position	Phoenix/Digi-Key	1729157	
<input type="checkbox"/>	JP3	4	Terminal Block, 2 position	Phoenix/Digi-Key	1731721	
<input type="checkbox"/>	JP4	1	Terminal Block, 2 position	Phoenix/Digi-Key	1729128	
<input type="checkbox"/>	Cc	1	Capacitor, 470pF	Vishay/Mouser	562R10TST47	
<input type="checkbox"/>	Cc	1	Capacitor, 100pF	Vishay/Mouser	562R10TST10	
<input type="checkbox"/>	Cc	1	Capacitor, 33pF	Vishay/Mouser	561R10TCCQ33	
<input type="checkbox"/>	R _s	8	Sense Resistor	KOA/Mouser (2ea) KOA/Mouser (2ea) Xicon/Mouser (2ea) Xicon/Mouser (2ea)	MOSX2CT52RR200F (0.2 1% 2W) MOSX2CT52RR300F (0.3 1% 2W) 262-0.47-RC (0.47 5% 2W) 282-2.0-RC (2 5% 2W)	
<input type="checkbox"/>	D4, 6	2	Diode, Fast Recovery	ON Semi/Digi-Key	MUR460RL	
<input type="checkbox"/>	NA	5	Rubber Bumper	3M/Digi-Key	SJ5518	
<input type="checkbox"/>	NA	1	Nut Starter	Menda/Jensen Tool	200	
<input type="checkbox"/>	NA	2	35mm DIN Rail Adaptor	Scidyne	121-0014	
<input type="checkbox"/>	NA	1	PCB	Power Amp Design	EVAL01	NA

Power Amp Design ♦ EVAL01 ♦ EVALUATION KIT FOR MODELS PAD01/02/08

CIRCUIT DIAGRAM

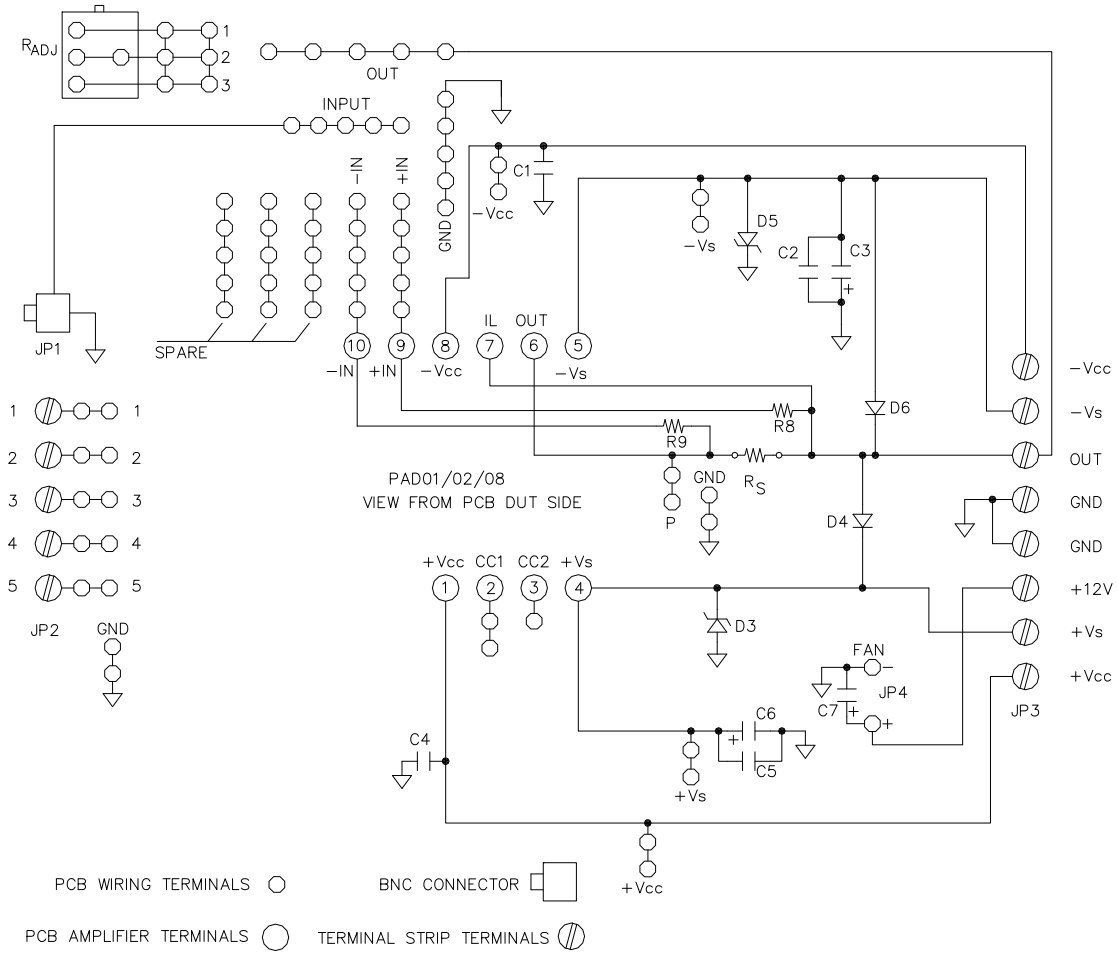

Power Amp Design ♦ EVAL01 ♦ EVALUATION KIT FOR MODELS PAD01/02/08

TOP VIEW

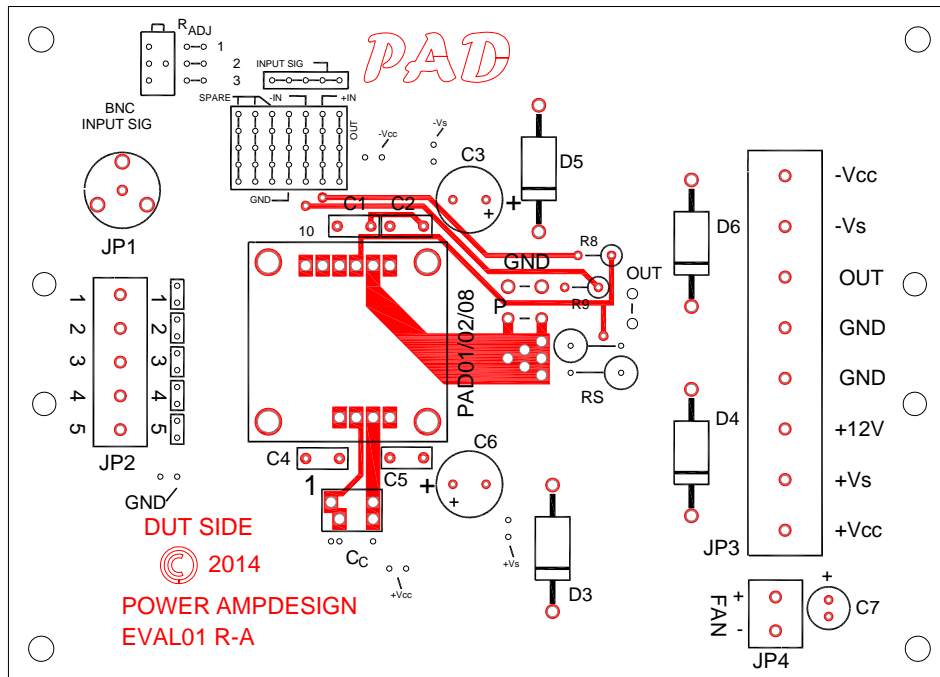

BOTTOM VIEW

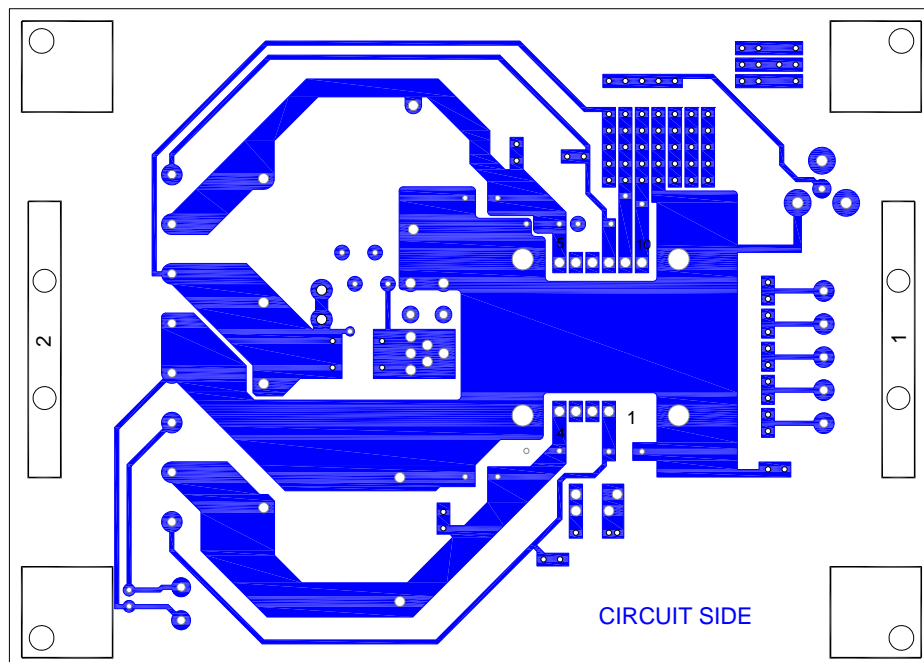

Power Amp Design ♦ EVAL01 ♦ EVALUATION KIT FOR MODELS PAD01/02/08

ASSEMBLED EVAL01 WITH AMPLIFIER MOUNTED

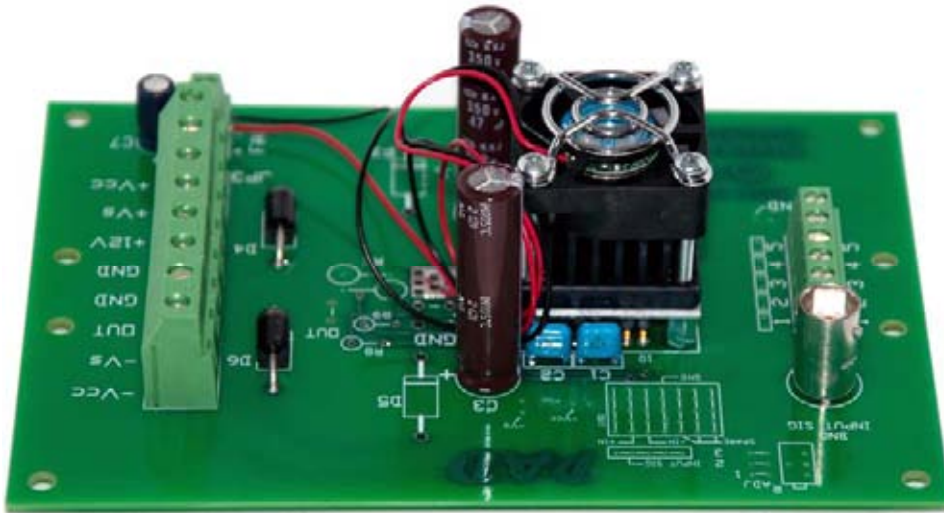
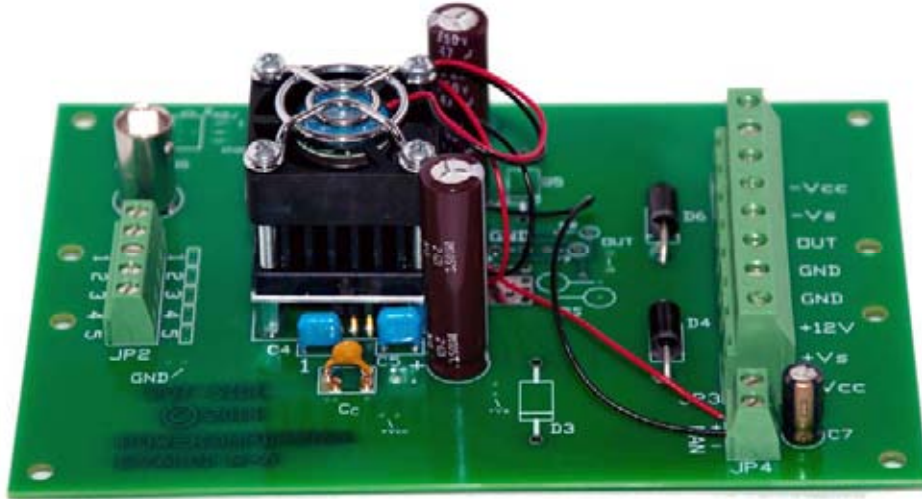

Power Amp Design ♦ EVAL01 ♦ EVALUATION KIT FOR MODELS PAD01/02/08

BOARD OUTLINE DIMENSIONS

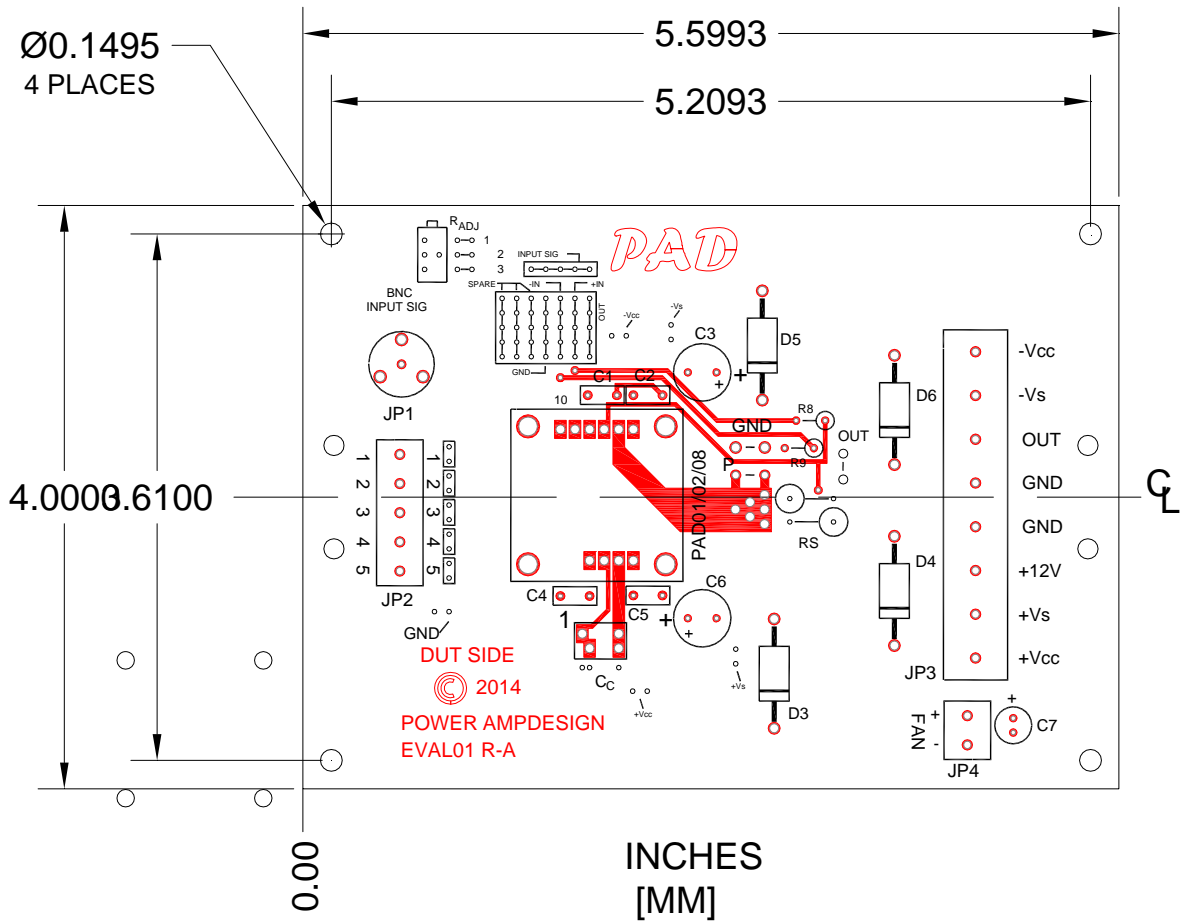

Power Amp Design ♦ EVAL01 ♦ EVALUATION KIT FOR MODELS PAD01/02/08